



in CAE's World

Follow us in the possible future....

Italian Passion for **Automation**

The Company

CAE is a young company of 25 people, specializes in the design and construction of machines and systems for industrial automation.

For 10 years now, the company has grown steadily, both in numbers and in skills and in aptitude for the challenges brought by customers.

This has shown the world market of automation, allowing us to export our creations in many countries around the world an increasingly proactive in addressing problems or needs of our customers by helping them to achieve the objectives, production or cost reductions.

Our best skill is to study and manufacture the machines adapts to demand, perfectly calibrated on the data received, with performance and reliability at the highest levels. Our company is specialized in machines resistance welding and our strength are the great years of experience in the field of resistance welding that allowed us to develop our products. In fact we have a complete line of components for welding, such as pneumatic cylinders, hydraulic cylinders, transformers, controls welding, all of the highest quality, always available in the store and branded CAE.

But this is not all.

We have experience, and fantasy, for make a lots of things....

We invite you to follow us at the discovery of CAE' s World.

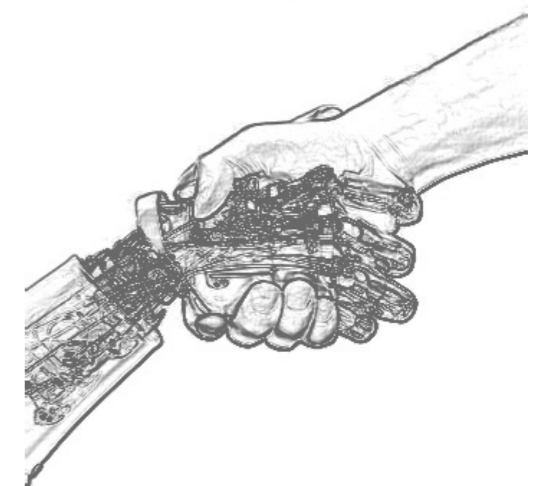

Introduction to CAE

Our philosophy is simple. So simple and straightforward can be arrogant, for those unfamiliar with our way of thinking and doing things.

We simply believe that business will do in two.

We sell technology and production systems, to help our customers to earn more or spend less. We know the net profitability of our machines, because is one of the bases for the formulation of the study and offer.

We know what make our machines, as important for you, and how long you will return.

Ensure that there never offer sales prices will be deviated from these considerations.

Our profit is perfectly reasonable, because we do not waste money on luxury goods in our Company.

Our company is modern, in order, certified ISO9001, organized and attentive to the environment, but painstaking economic administration to not load avoidable costs on our offers.

If our offers are different and higher than the competition, is only because we give you more, and we invite you to compare in detail the technical solutions proposed.

We do not care what our competitors do and what they give and want... We are different.

Not infrequently we see that both Client and Supplier are dissatisfied and this represents a defeat for us must be avoided.

During the negotiations, do not expect greater discounts. We will stop the inevitable threshold, giving up order in respect of professional ethics will appreciate then, if you choose.

Finally, we want to bring our technology and our service to modern Company that can benefit from us, establishing a profitable relationship for both, going beyond simple Customer / Supplier relationship.

Drawings and pictures

We have chosen to show mainly three-dimensional models of our machines, because we are proud of the level of detail of our projects and to easily position the imagine generators to highlight some features.

In some cases, we have included actual pictures of the machines to enhance certain parts, or pictures or drawings of the object product, or in some cases directly the final product of the field of membership without having to show detailed, for confidentiality against of our Customers.

You will find many machines, all different from each other, and these represent only a small overview of our productions.

Certainly there are many, and very different kind, but still an infinitesimal part of the possible customizations and new creations that we can develop, so that you achieve manufacturing excellence and quality in your business.

We would like to reassure you, as you browse through this brochure, that the cost for customized machines are quite affordable for the small than for large companies.

The feasibility study and offer price that we will be happy to show you, absolutely take care the amortization periods and methods of payment you need to acquire a machine CAE built for you, around you.

Our target is to "make our own", with the utmost care, the needs and demands of our Customers, serving as a first-tier partners to create a relationship of trust and transparency, with knowledge that such collaboration can get a fruitful mutual development.

Resistance welding machines

Next to each machine, you will find a picture for understand easily wich kind of tecnology was used.

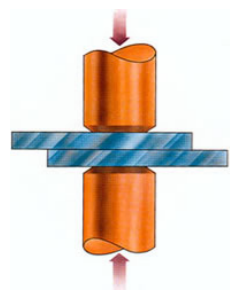

Spot resistance welding

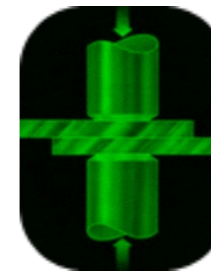

Mid.frequency spot resistance welding (1000Hz)

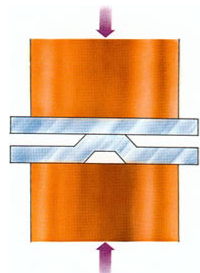

Projection resistance welding

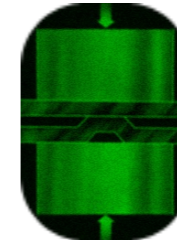

Mid-frequency projection resistance welding (1000 Hz)

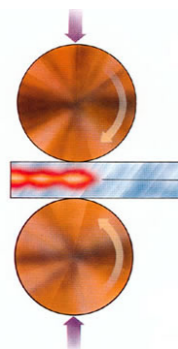

Seam resistance welding

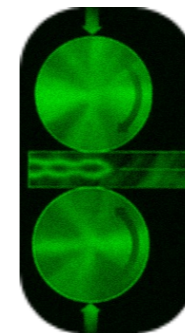

Mid-frequency seam resitance welding (1000 Hz)

Special welding machine for washingmachine production

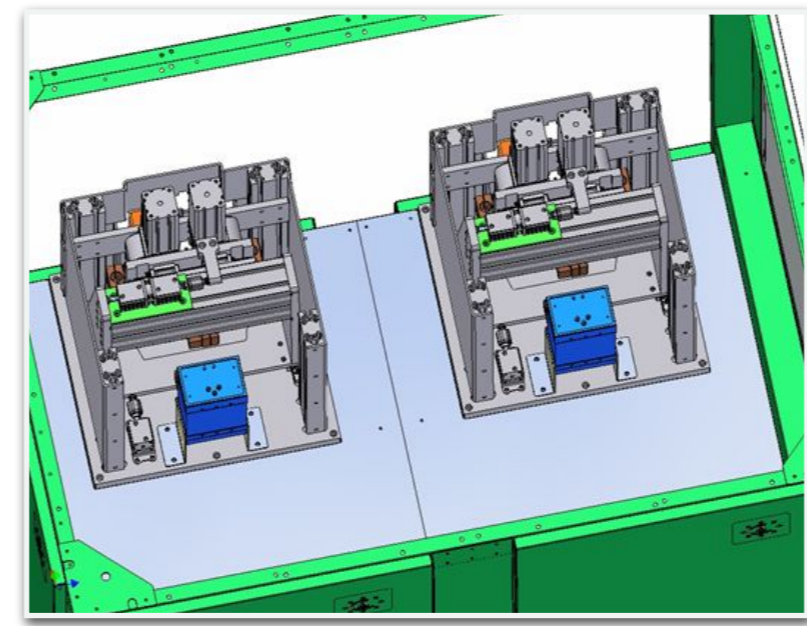
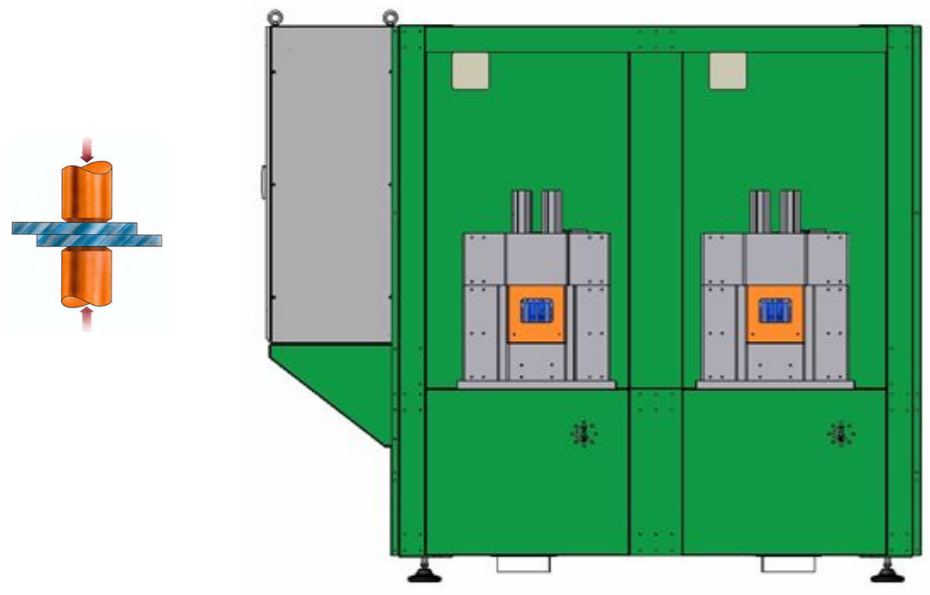
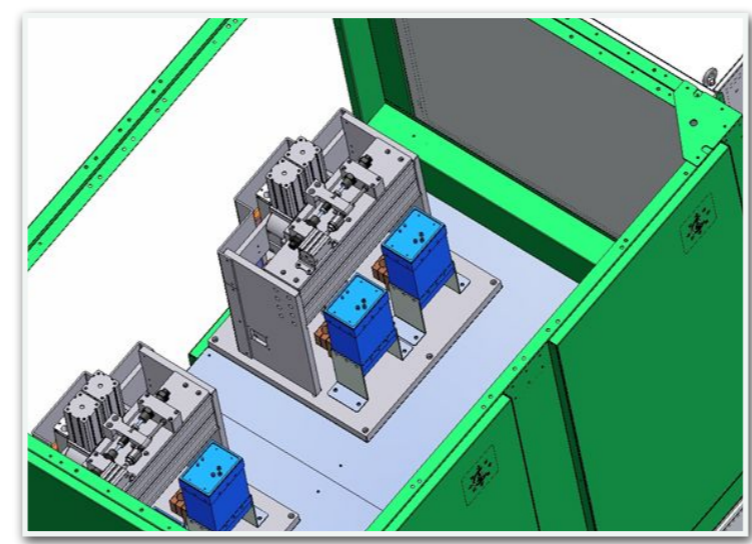
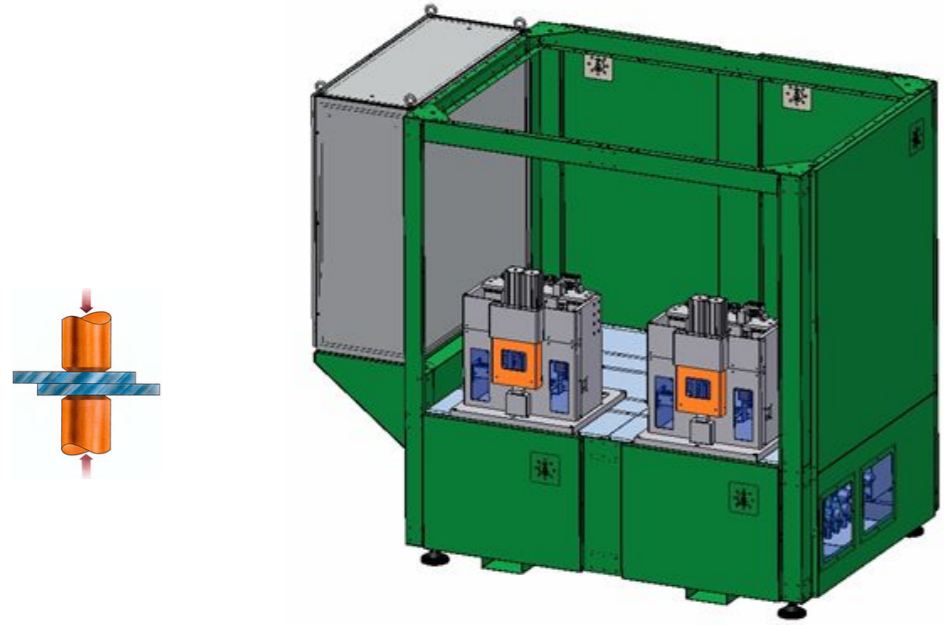

Special welding machine for water-heaters and hoods production

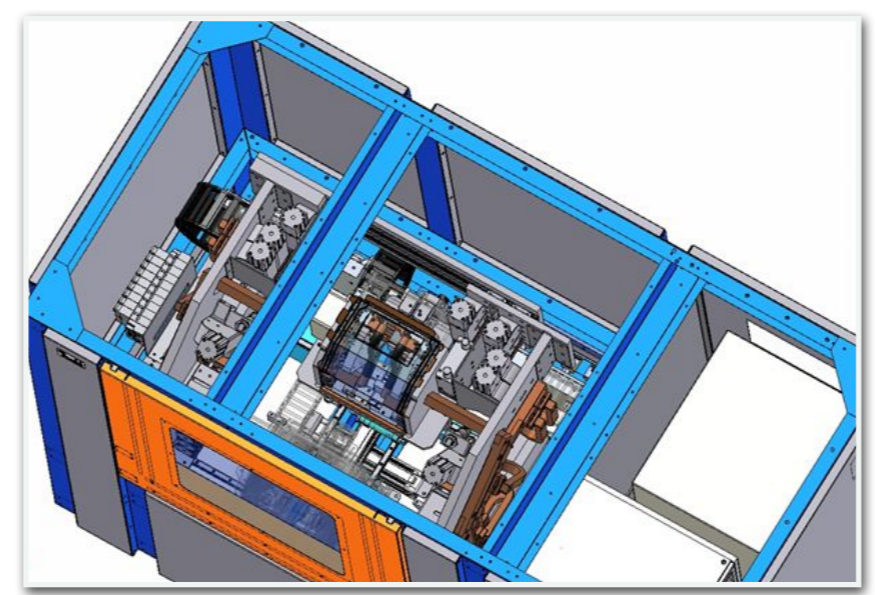
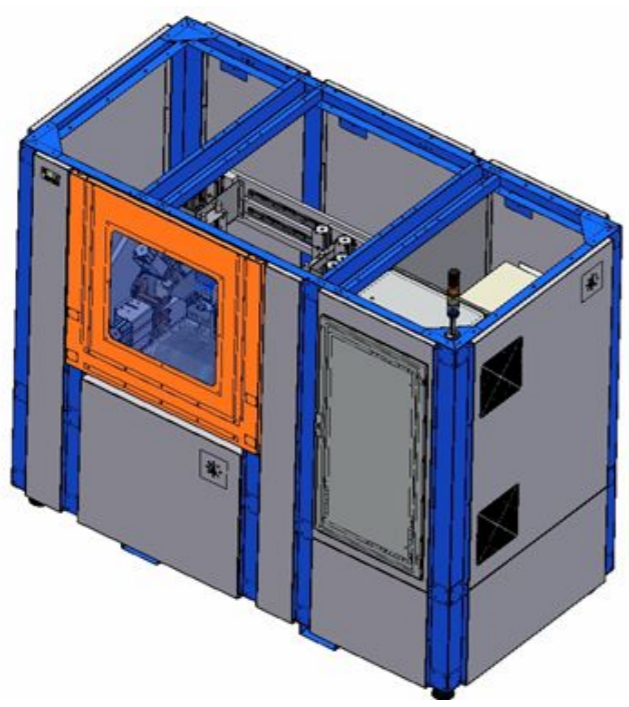
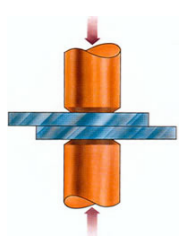
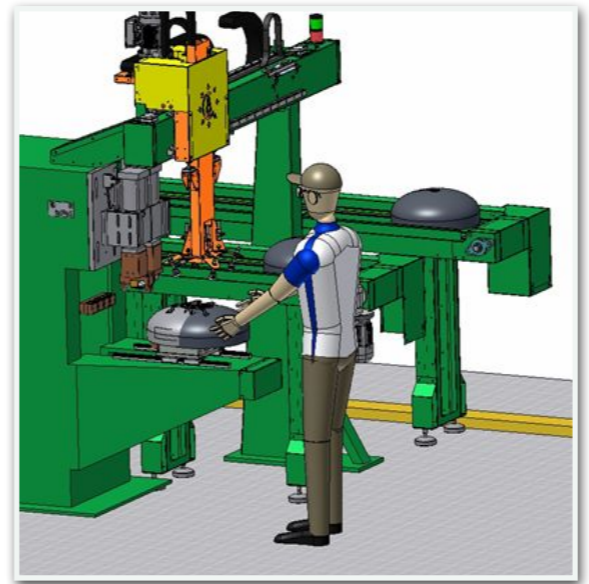
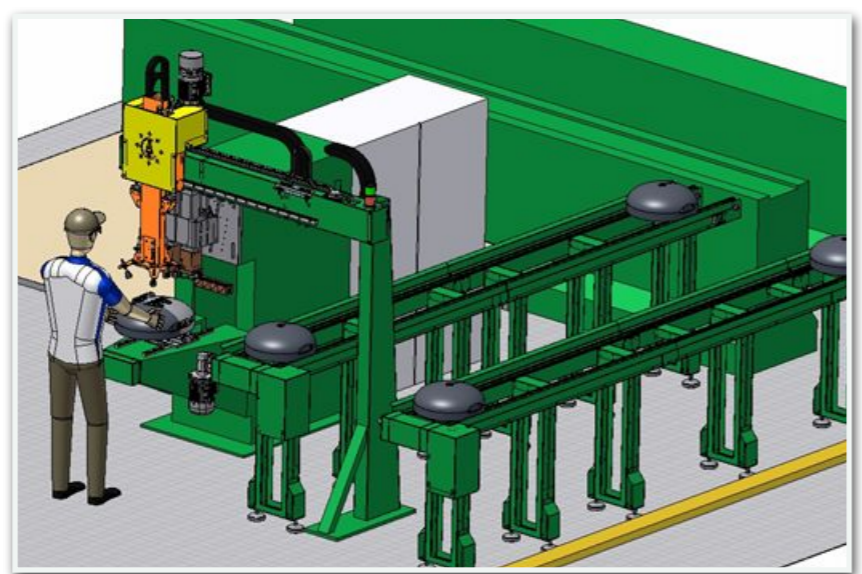
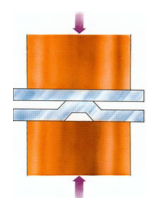

Automatic self feeder machines for washing-machine cabinet welding

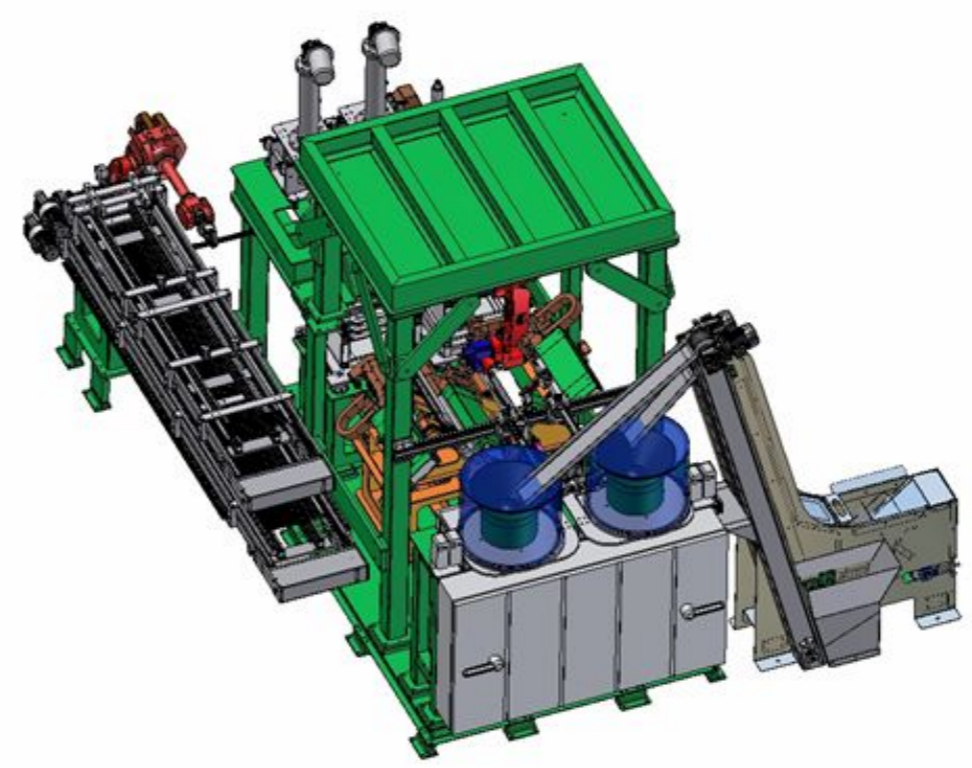
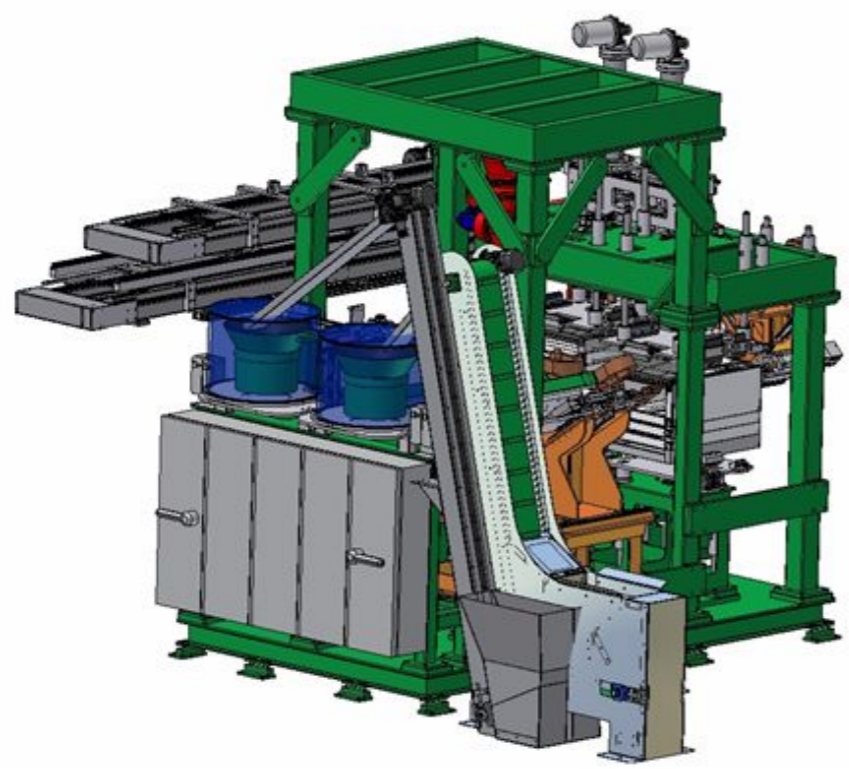
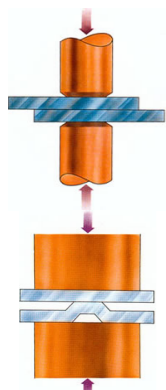
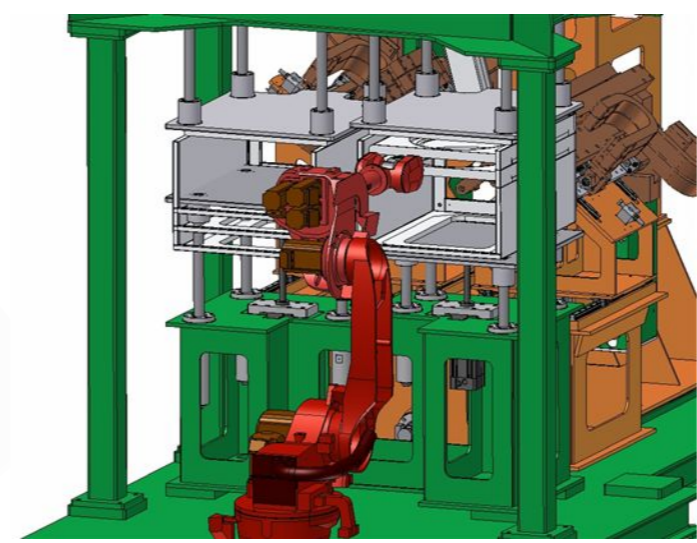
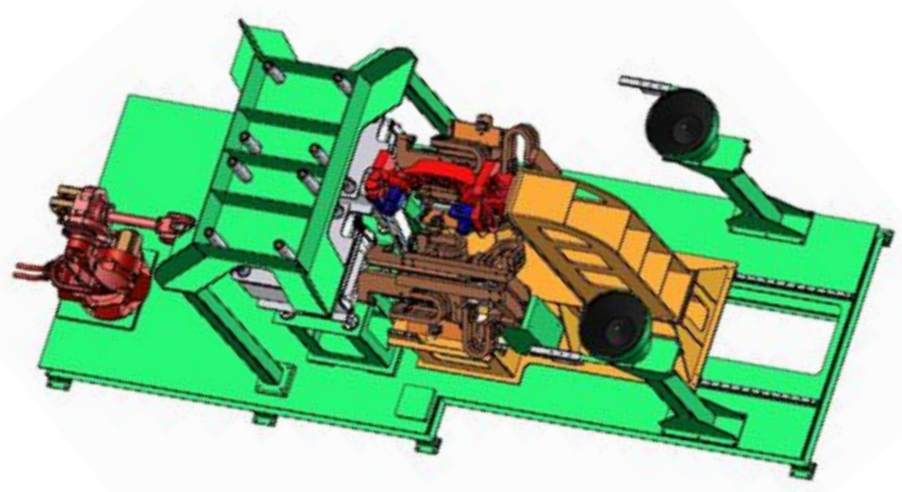
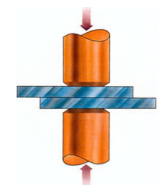

Special welding machines for hoods and interior parts for automotive

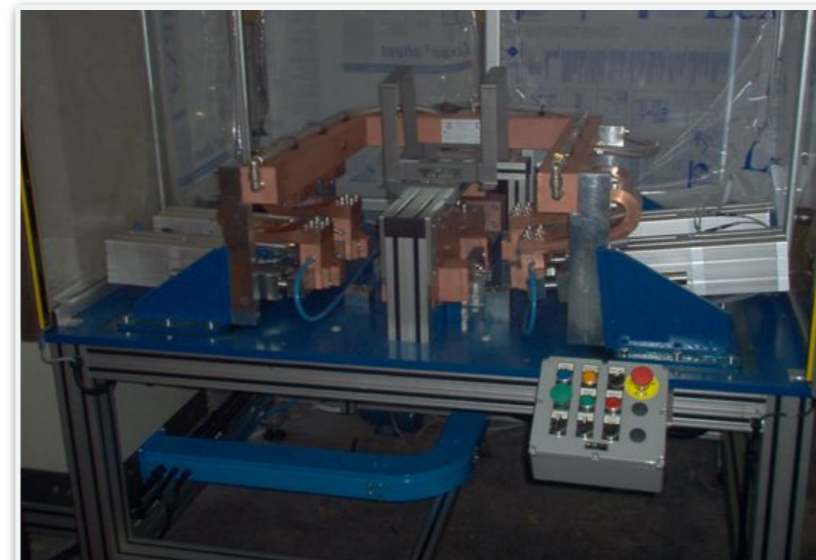
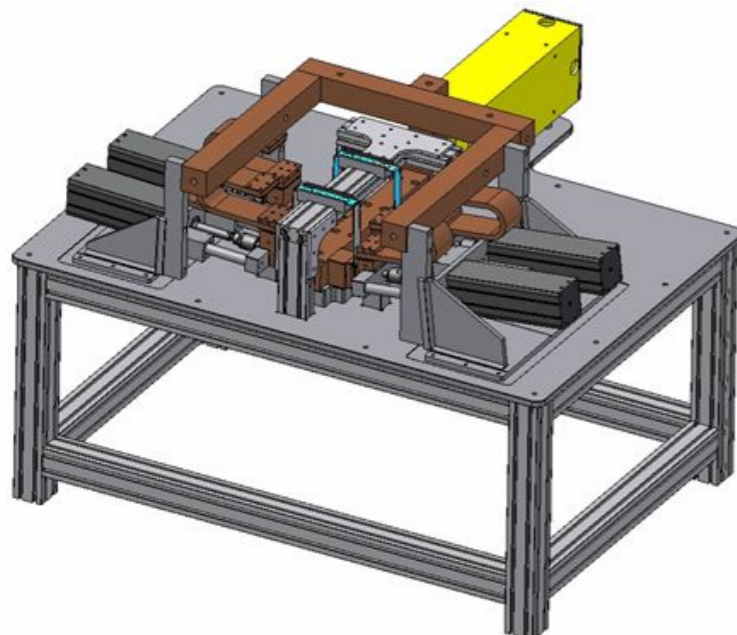
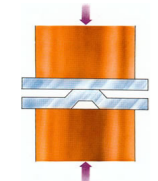
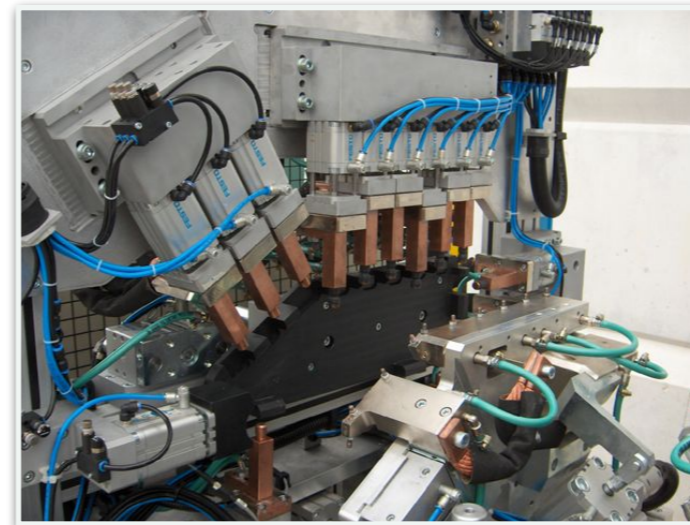
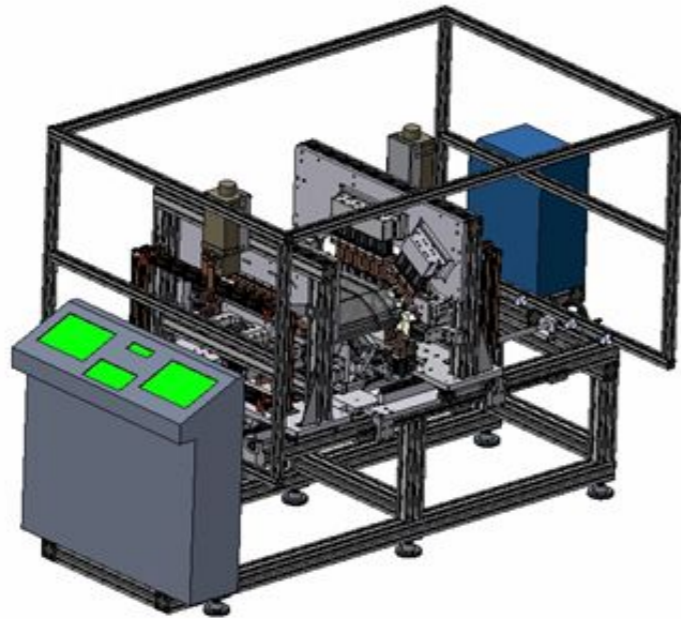

Others example of welding machines for complete production of cabinet for washing-machines

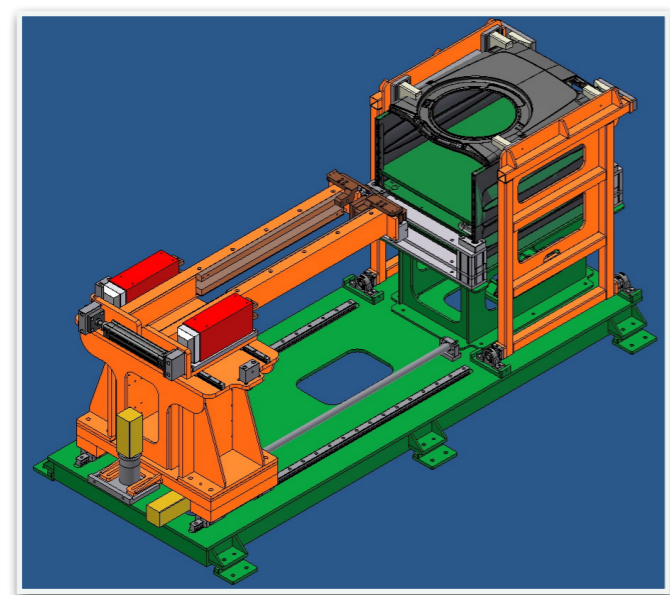
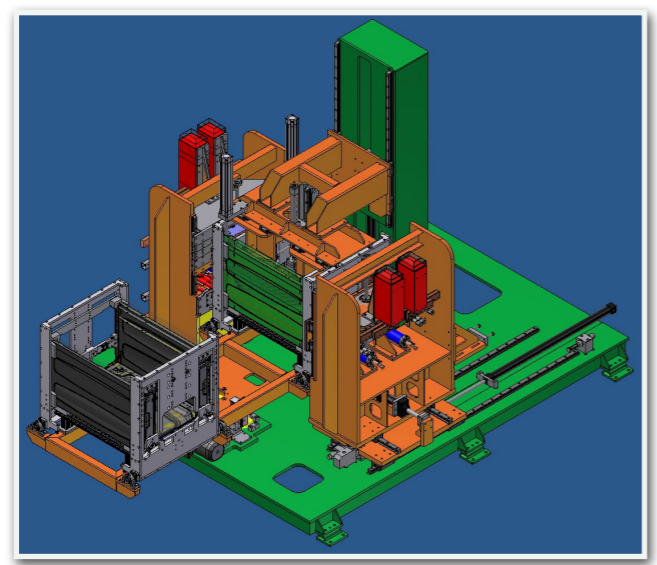

Special welding machine for toolbox production and for resistance heaters

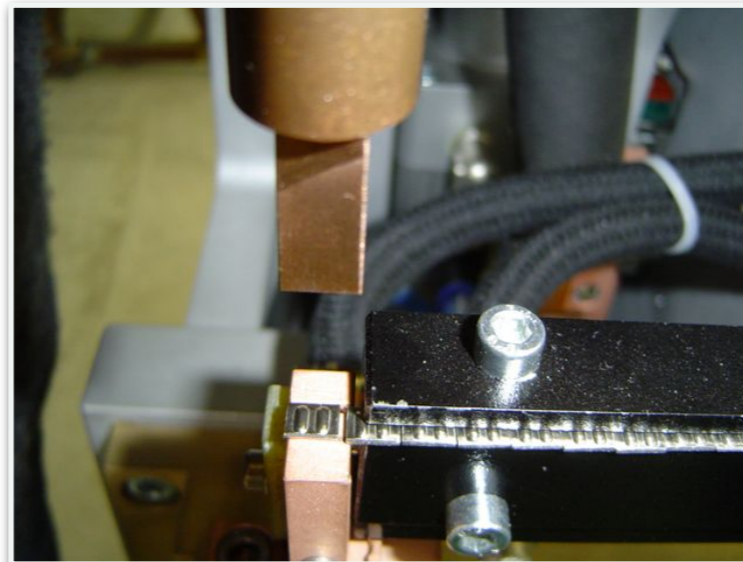
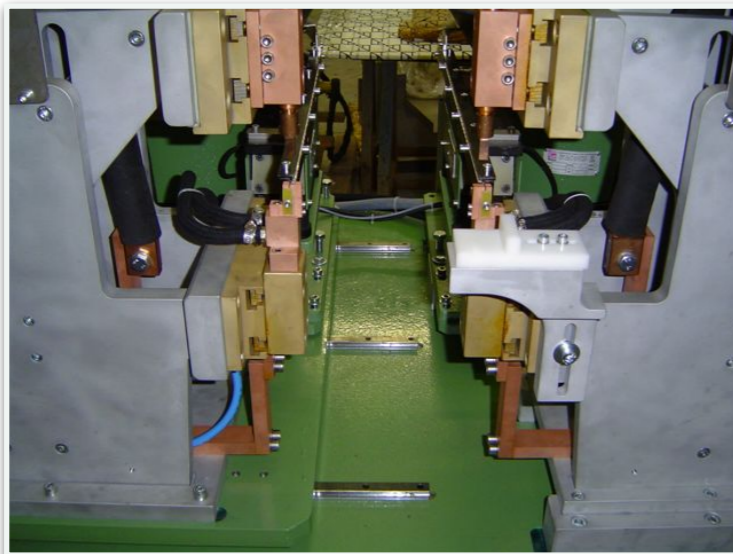
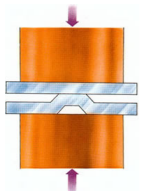
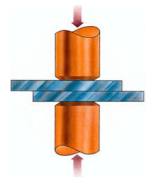

Special mid-frequency seaming machine especially designed for drum welding, dry welding on Aisi 430, with excellent heating control.

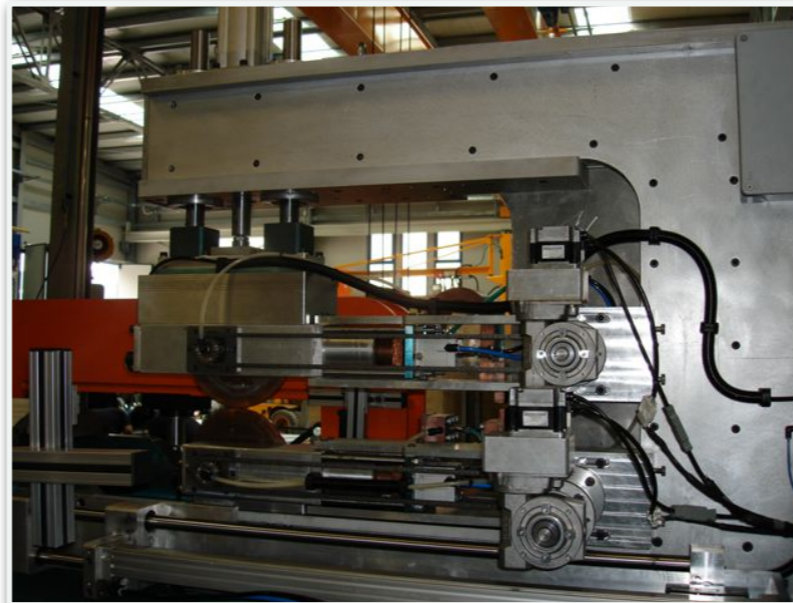
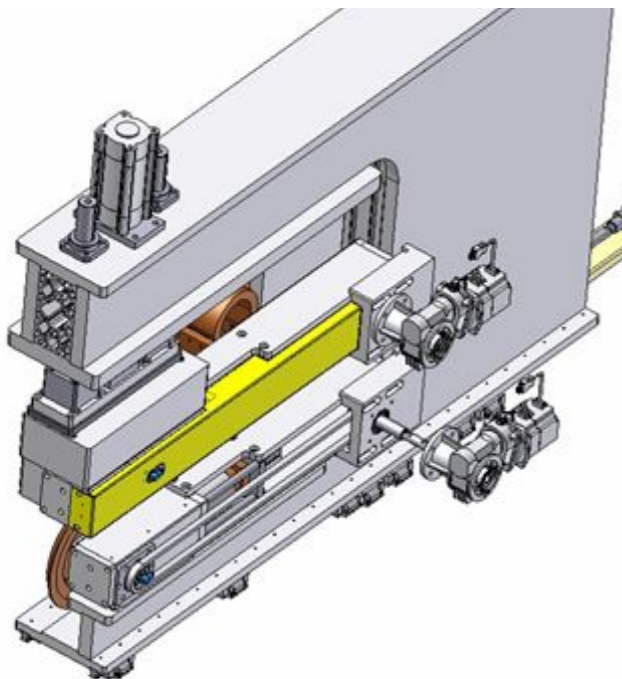
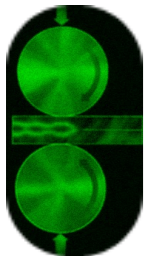
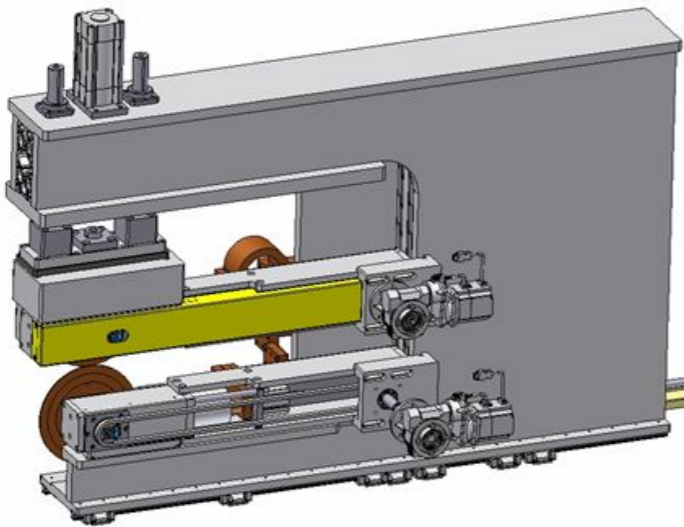

Other kind of special welding machines: for tubular structures, for heaters and for cooking resistance and for water heat panel absorbers.

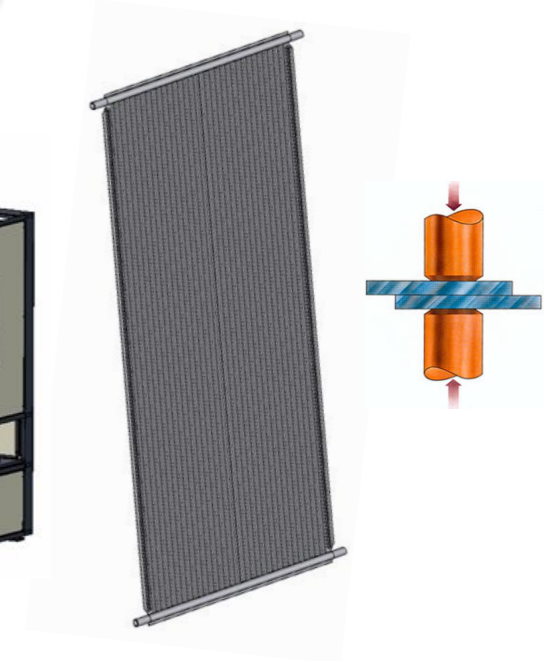
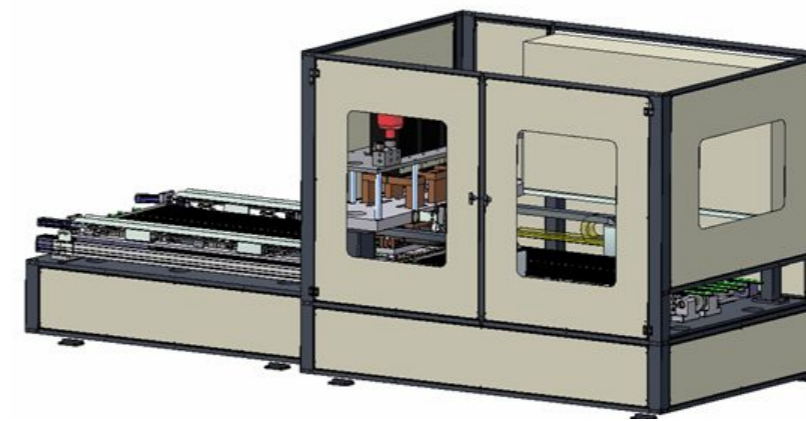
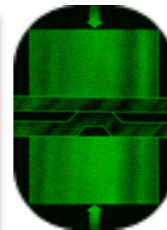
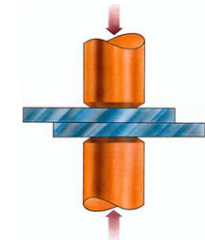
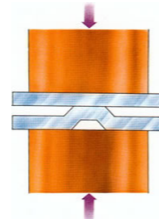
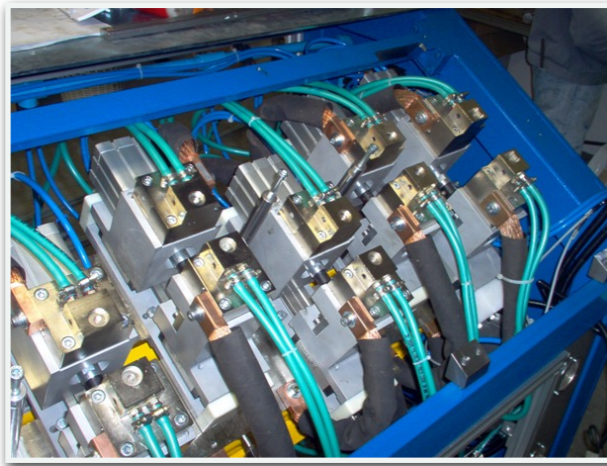

For resistance welding, we have a real passion, and over the years from simple integrators, we have become "producers of components."

In the sense that the standard products of Tecna Bosch, Myiachi, CEA, and so on, at one point were not flexible enough to marry with our needs and those of our customers, because of the need to offer something unique.

Welding transformers ISO10656

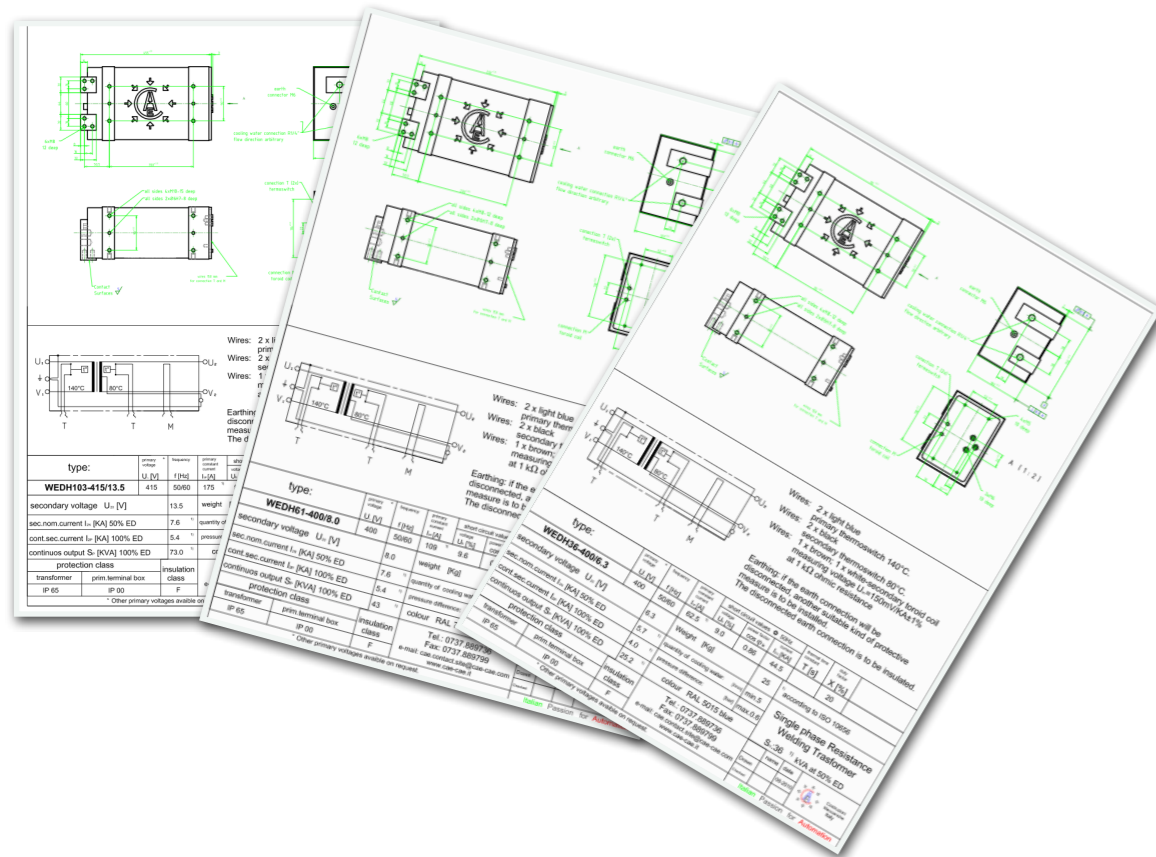

Welding Cylinders

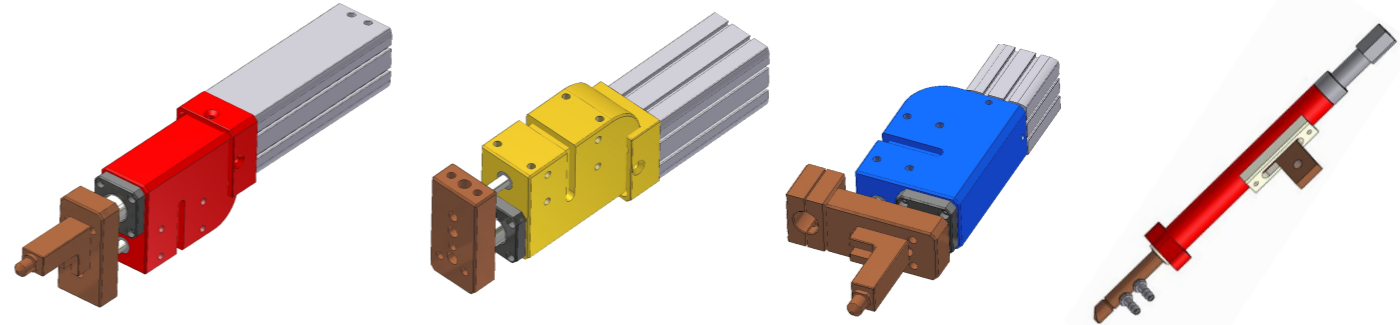

Copper braid connection kit



Welding control 50/60hz.

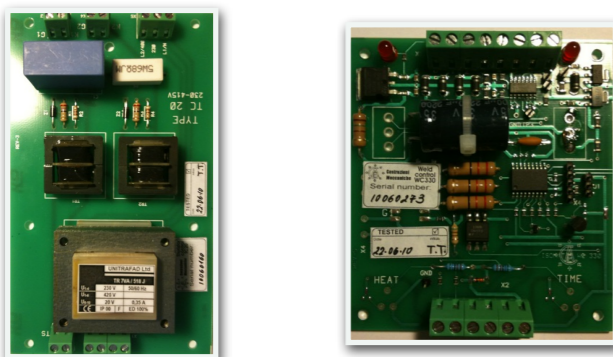

Thyristors



Mid-frequency welding control 1000hz.



Clinching systems

We offer our Clinching solutions for every need.

In robotics solutions, in dedicated machines or in combined systems.

We use the two most popular brands in the world of Clinching system : TOX and BÖLLHOFF.

This is to give our customers the assurance of total quality in the final product.

Clinching systems, can be completely customized, like other systems, to obtain the best compromise between investment and return.

Clinching usually, can replaces welding in prepainted assembly, if you want to prevent corrosion, or for joining different materials are not compatible and weldable.



Some example of our Clinching applications: in top loader washingmachine drum and on prepainted steel cabinet.

TOX[®] PRESSOTECHNIK

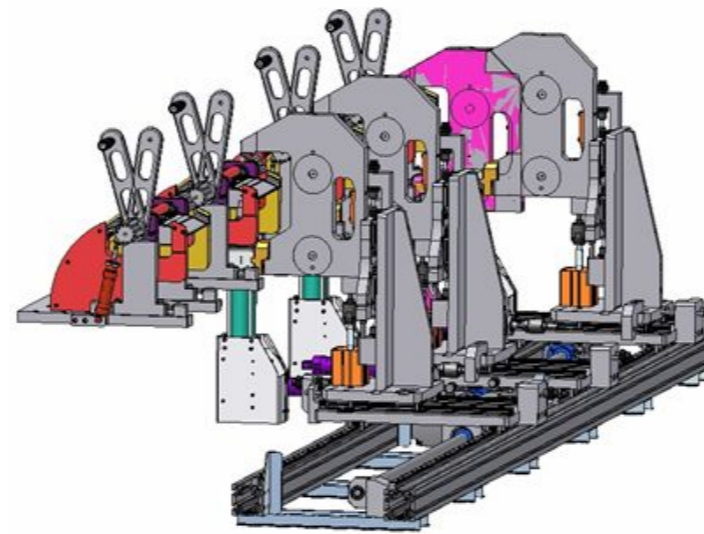
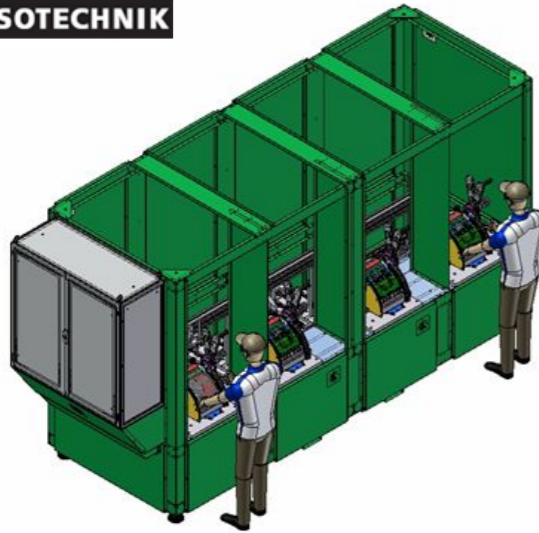

BOLLHOFF

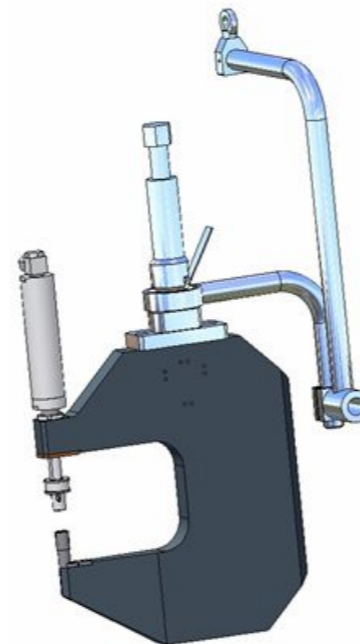
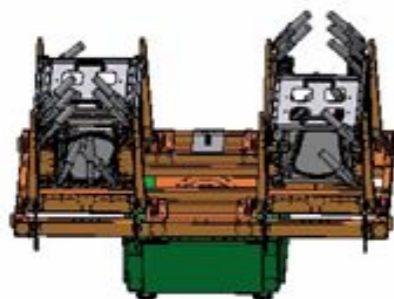
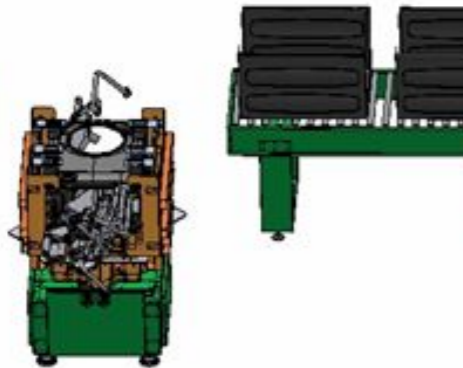

Bending systems

We build any kinds of machines for sheet metal bending, absolutely accurate and easy to manage.

From low-cost single machines to multi-axis numerical control systems, alone or integrated into fully automated systems.

Our flexibility is high enough to be confident to propose exactly what you need.

We can make bending machines with pneumatic, hydraulic and electric "tilting" flat systems, totally and freely programmable, with hydraulics or electric blank holder and also with interpolation CN systems in case of very difficult bending problem.

Our solutions are always tailored to the needs of the Customer, always trying to bring the product to meet the balance between investment and economic return.

Why buying a standard folding machines designed to go "well" for all? These kind of machine, goes really "well" for you?

Choosing our machines, built around you, is without any doubt the best investment in terms of efficiency that you can do for your business.

The blue machine, can bend sheet metal up to 2 mm.
The green machine instead was created as an entry-level machines for bending cabinet of washing machines, dishwashers or refrigerators.

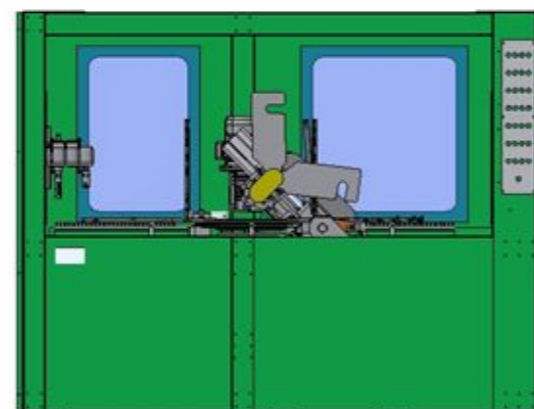
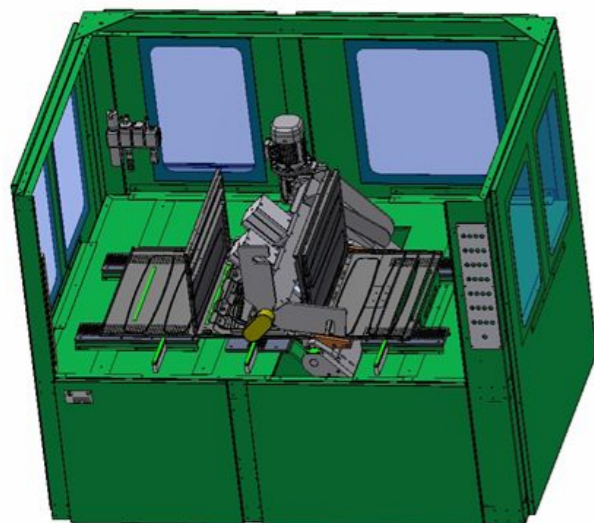
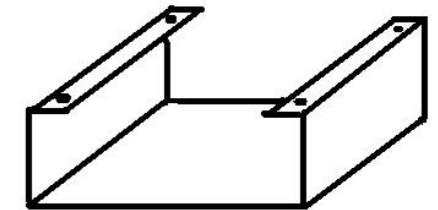
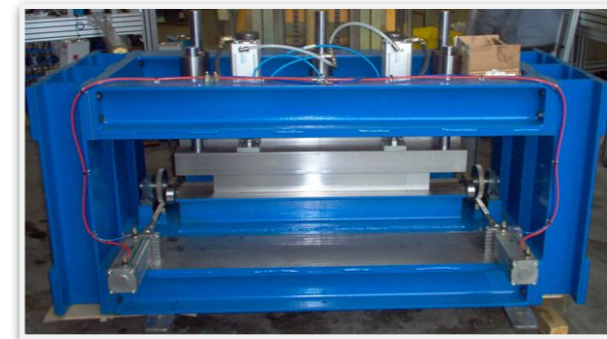
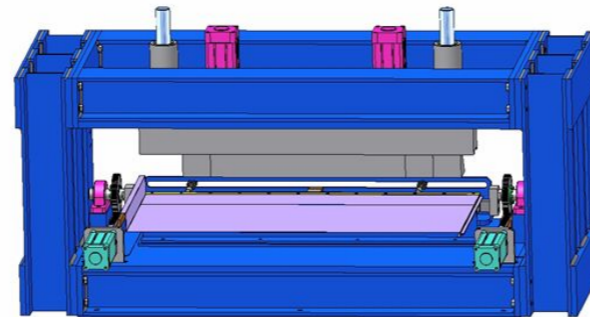
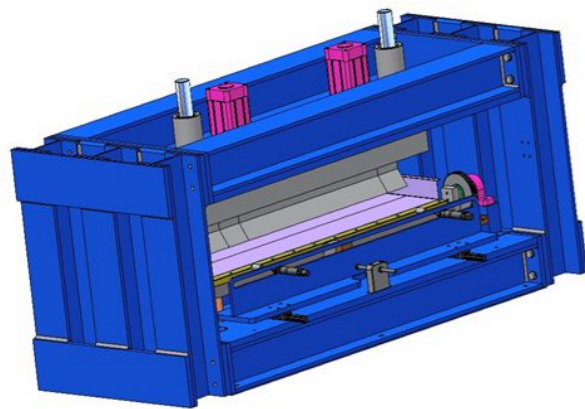

Automatic bending line for different kind of materials, with electric "tilting" flap and four station charger, able fo sheets 1200mm x 1200mm. The line is designed to work in production mix 1-1 with capacity exceeding than 4 pieces / min. This plant has been built for the creation of "chimneys" for hoods of all sizes. The programs folder, are created directly by the Customer through a simple and intuitive interface. All the system is very economical to purchase and virtually maintenance free.

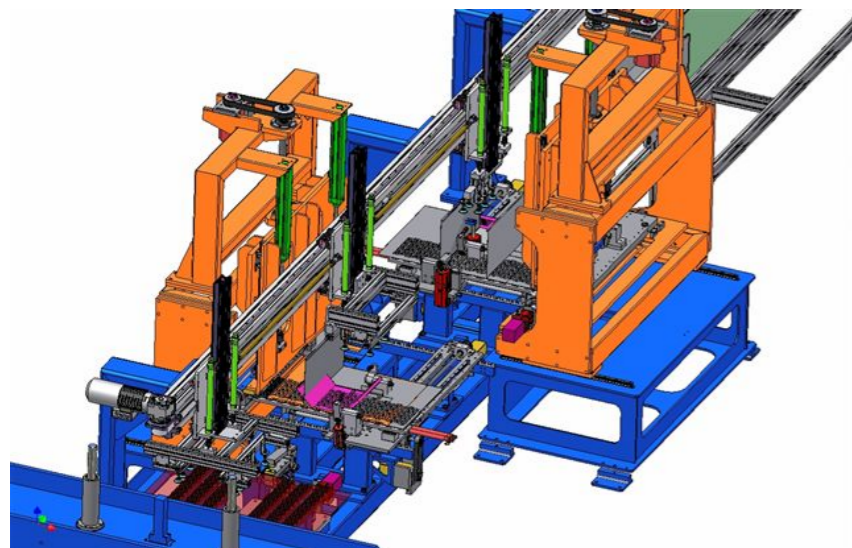
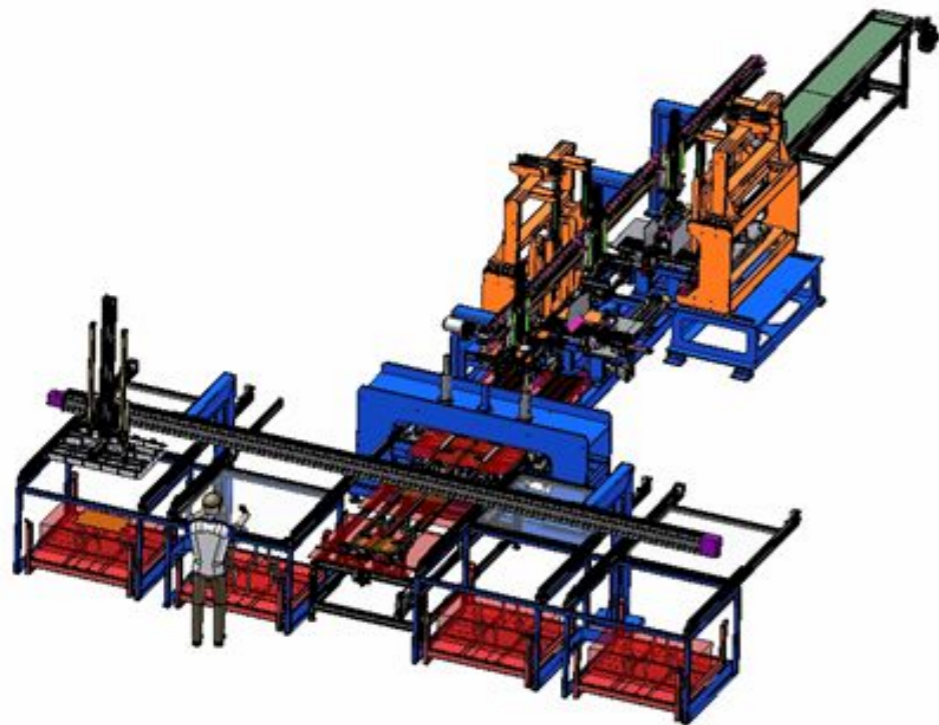

This production line represents our highest expression in terms of technology in the process of shearing and bending.

It can process all types of materials: all stainless steel, iron, aluminum, copper, brass, tin and painted with protective film, thickness from 0.3 mm thickness to 0.9 mm. The machine is very versatile and can process different models simultaneously, both of geometry, thickness of material.

Production is over 180 pieces per hour with an efficiency of over 94%.

In total there are 43 servo motors, development of a long line of 40 meters to allow this marvelous versatility and this excellent feature.

The finishing touch to an automated system so efficient, is a settlement system for parcels with an anthropomorphic robot, equipped with our CAM system that can automatically create the necessary coordinates for the resolution of the best packages, from the code design and measures of base sheet.

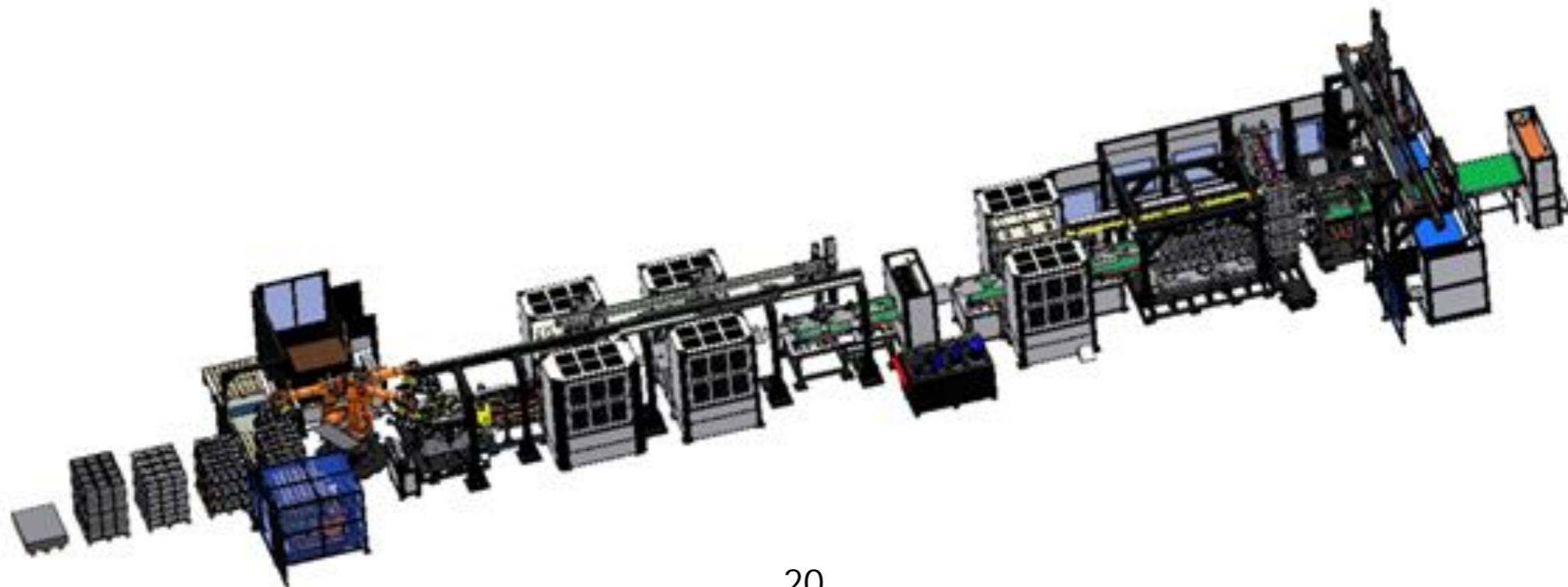

2° page about 43 axis for shearing and bending production line

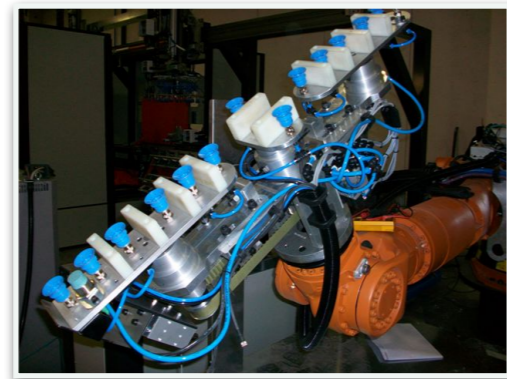
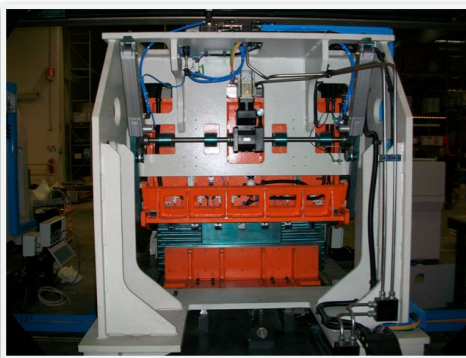
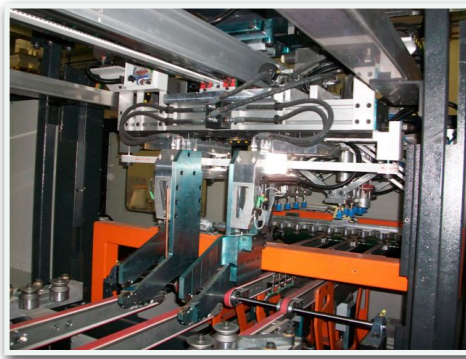
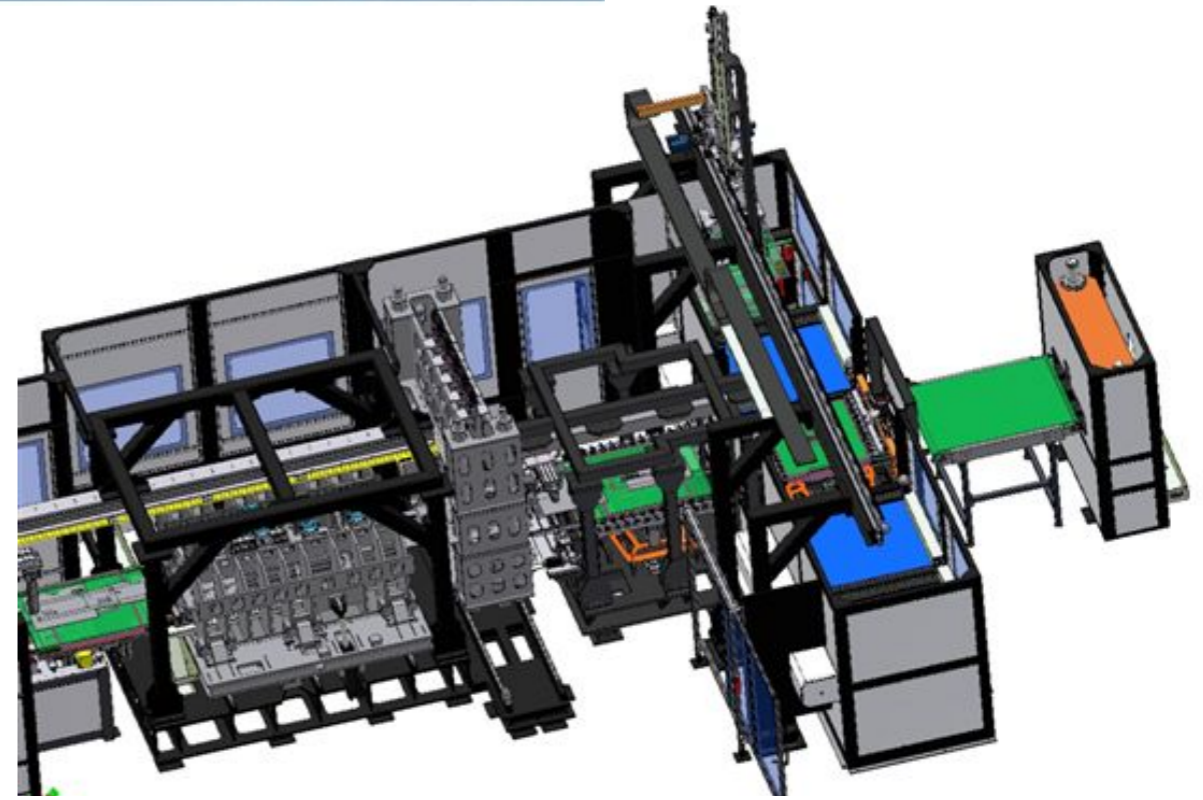
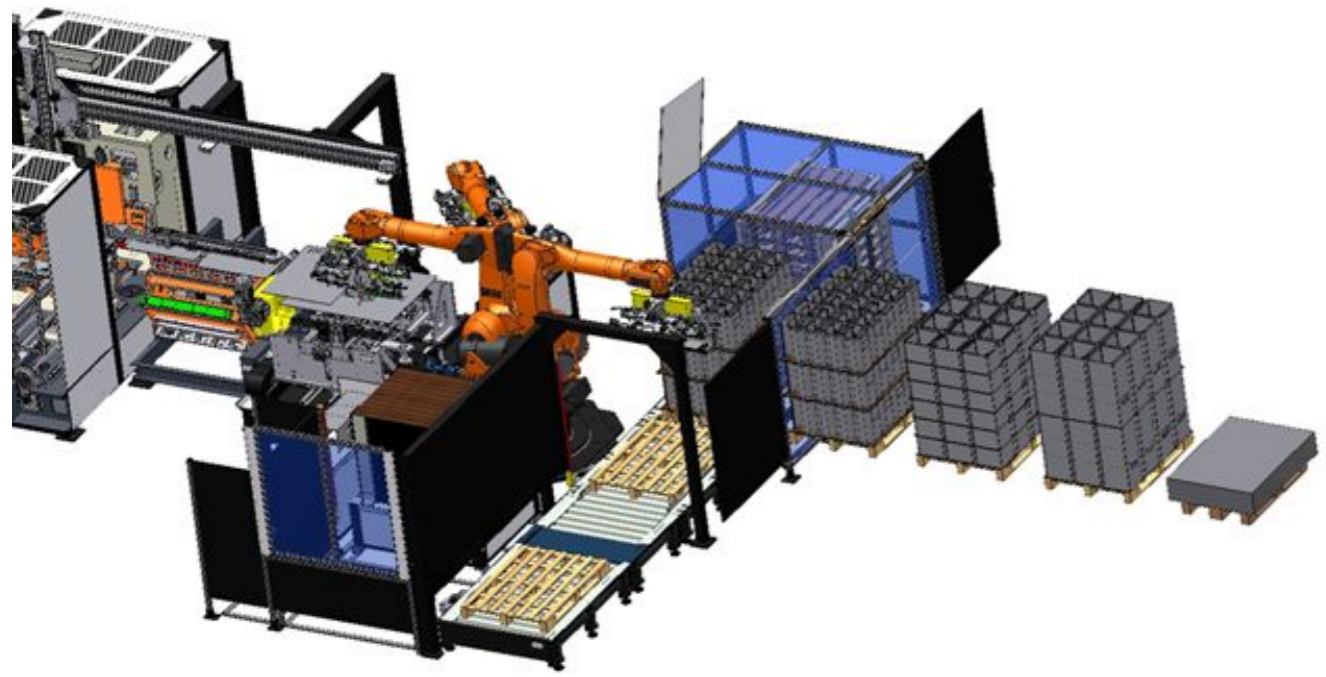

Special handling machine for many uses. In the picture an electric machine for management "guard-rail" profile, before and after galvanizing.

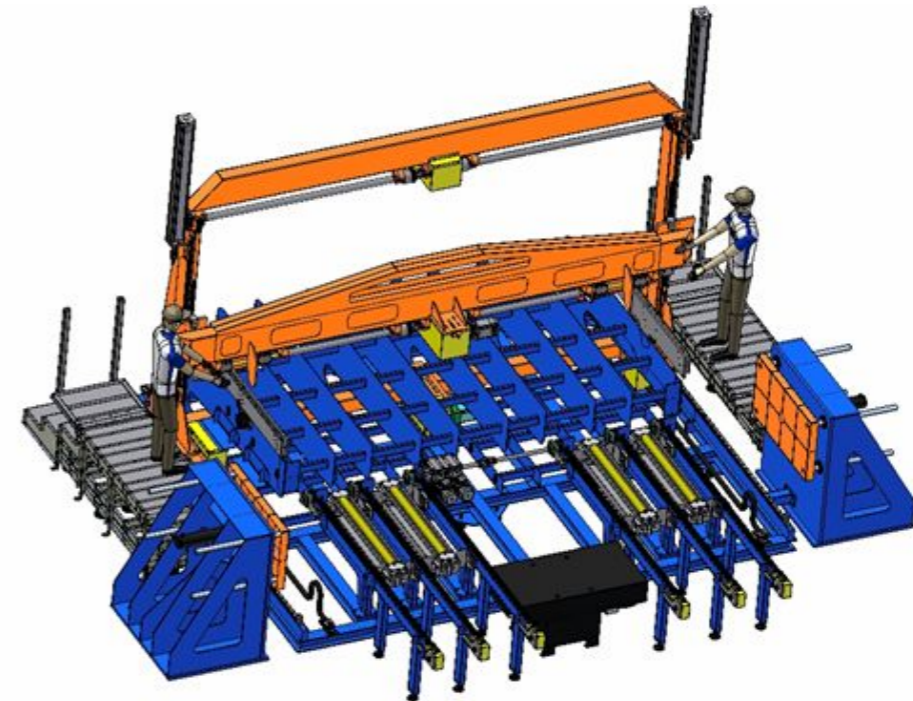
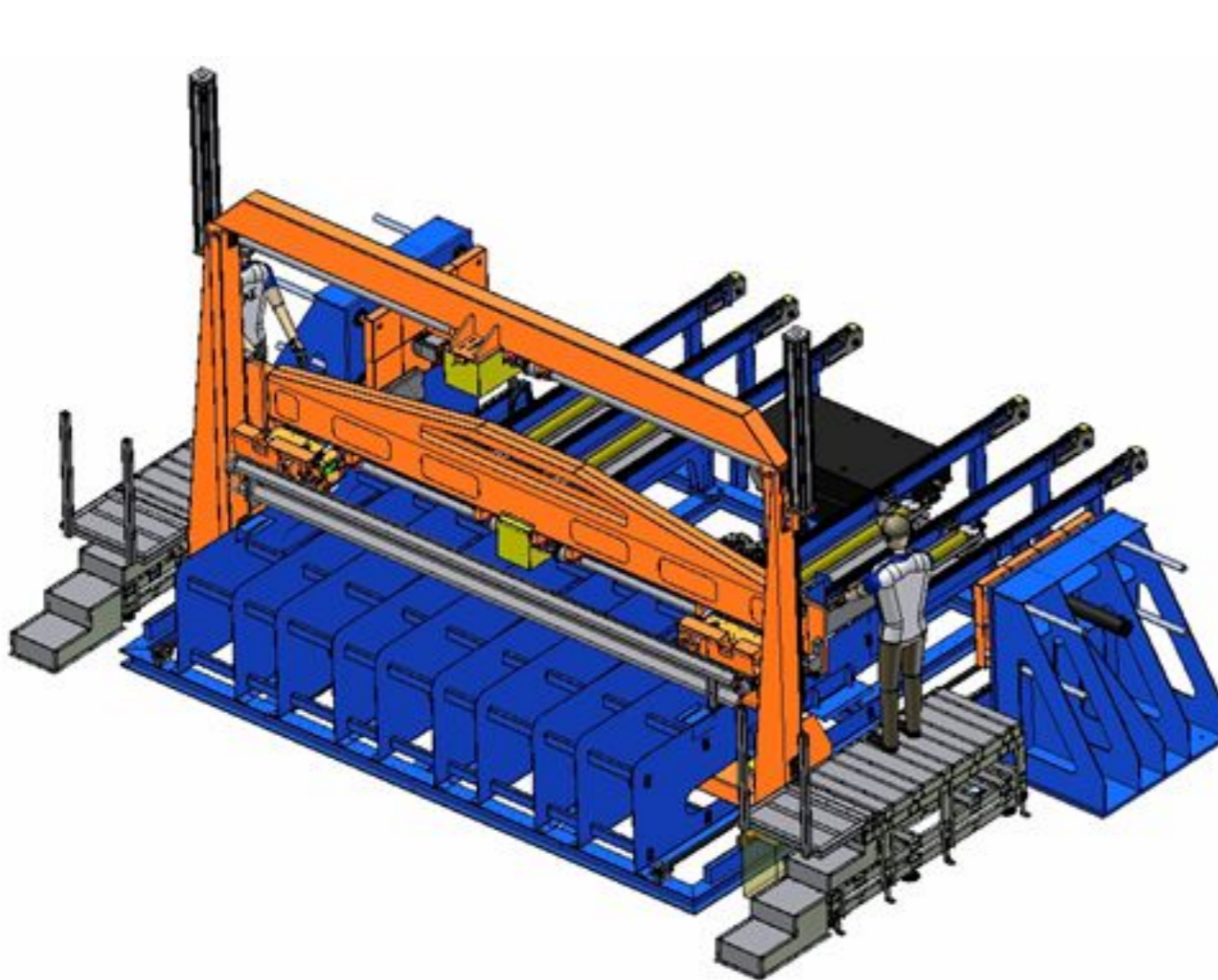

We made machines and handling systems for washing machines, dishwashers, water heaters, drums, for baths tube, for metal sheet, for screw and for plastic components. This page provides an overview of some of our achievements.

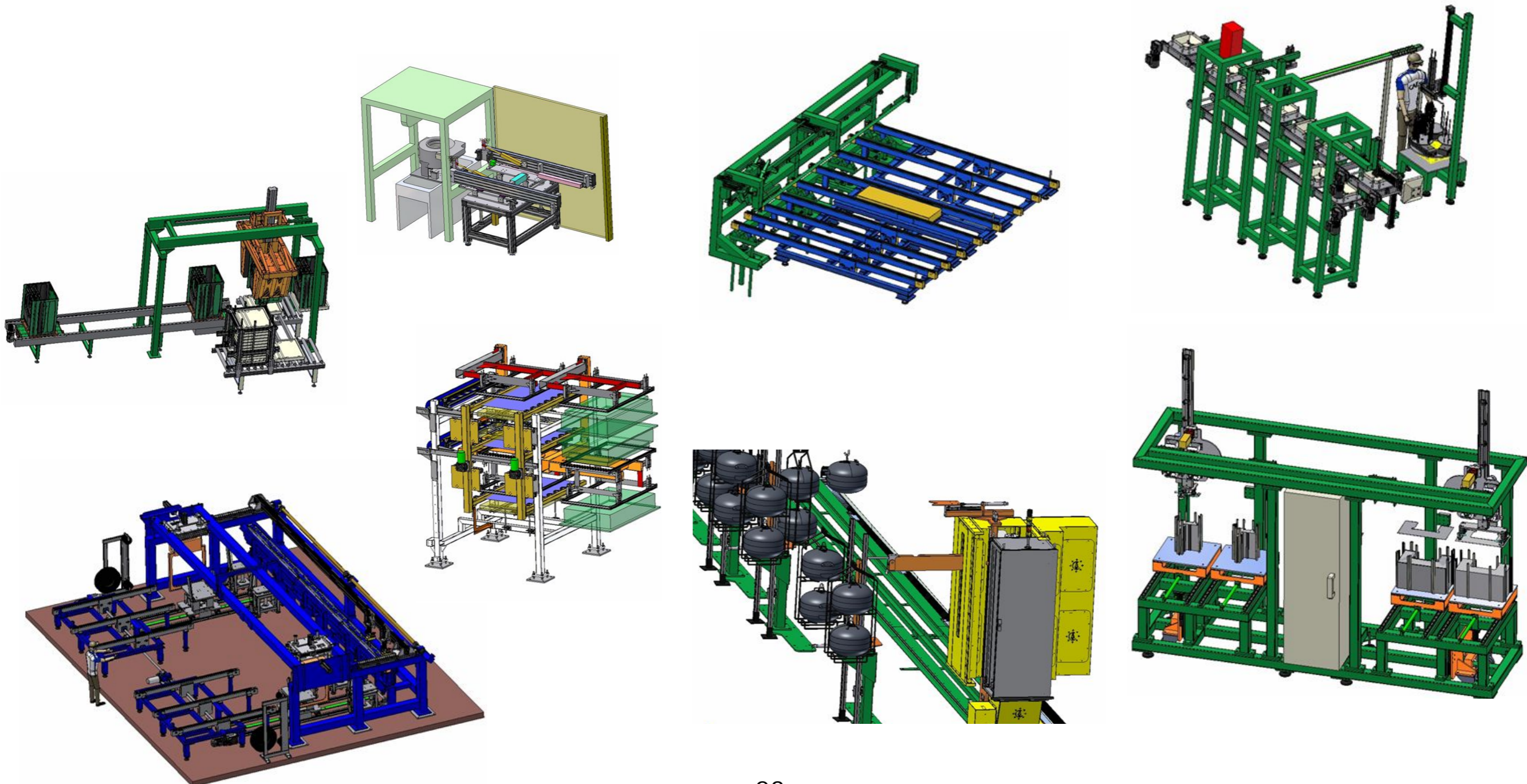

Special machine for assembly and test electric motors for fans

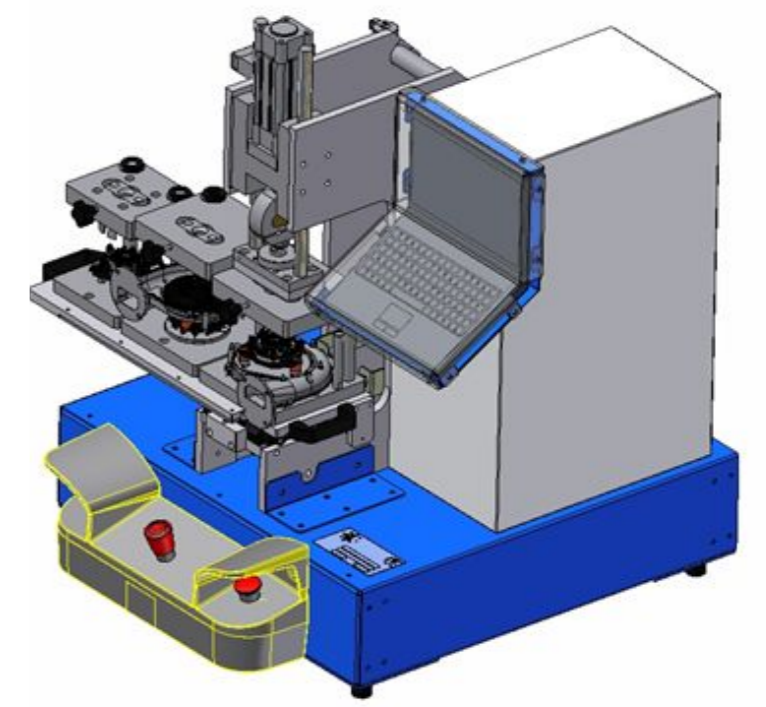
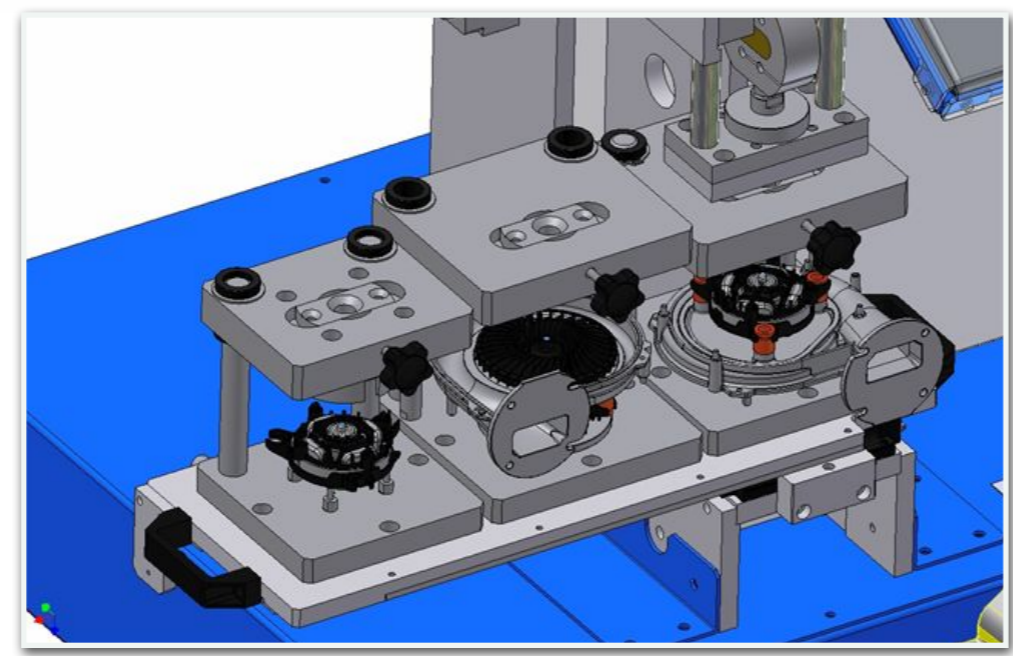
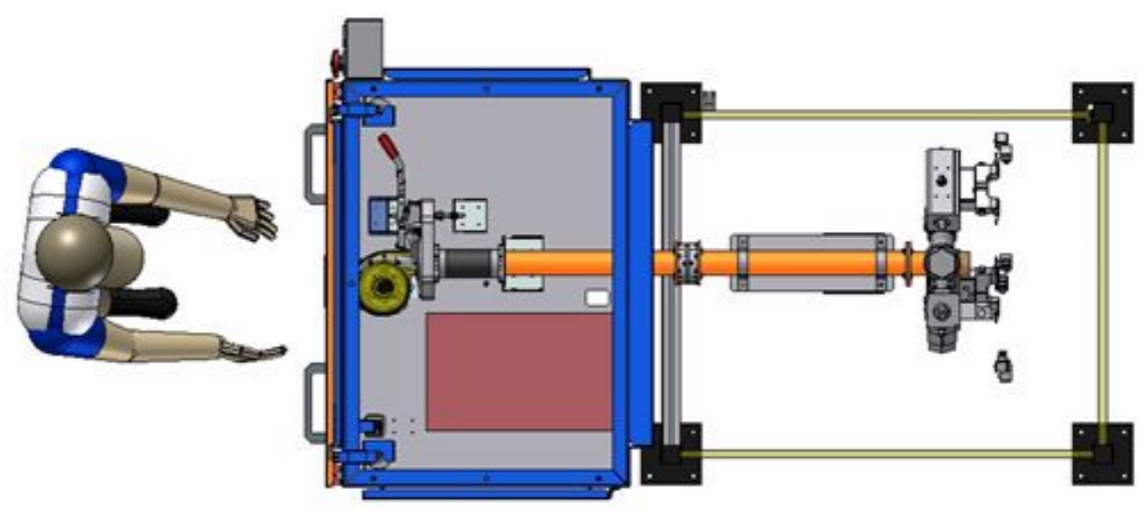
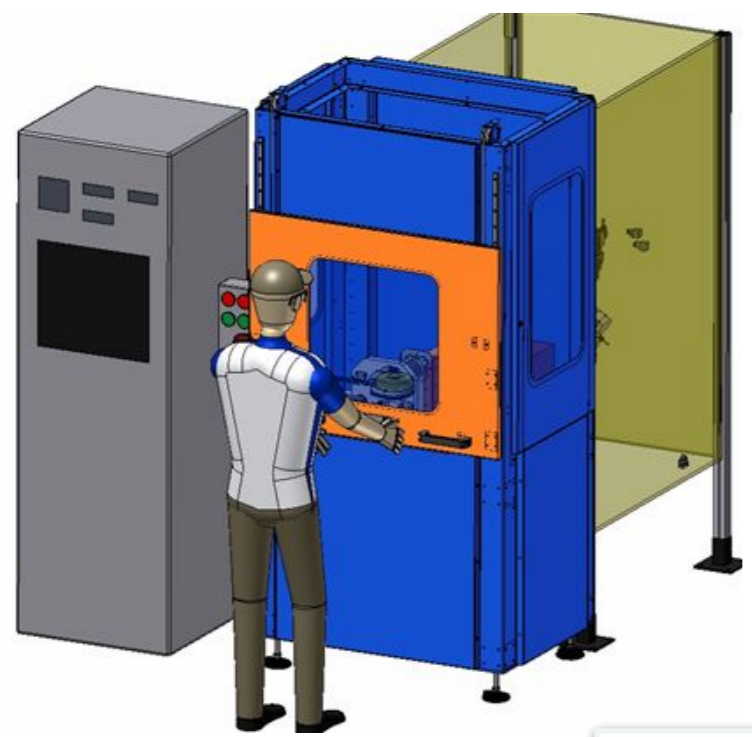

**We made special machine for "lifting" and handling of any kinds.
We can build also any kind of assembly machines.**

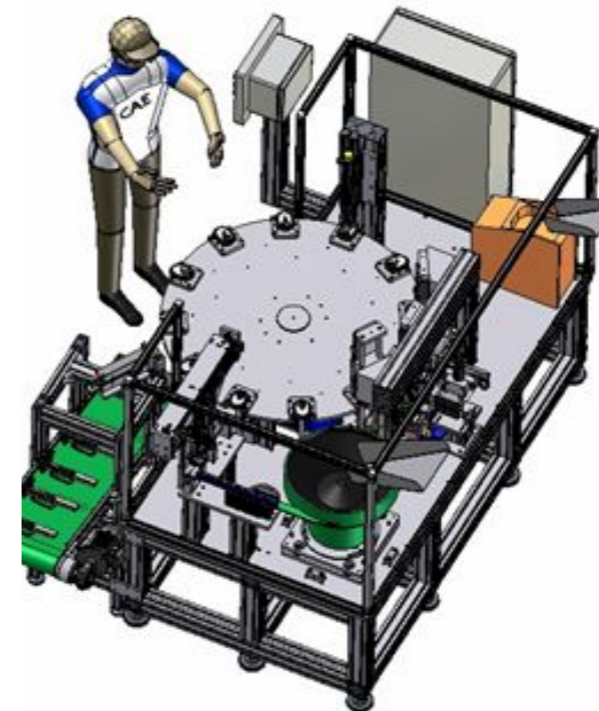
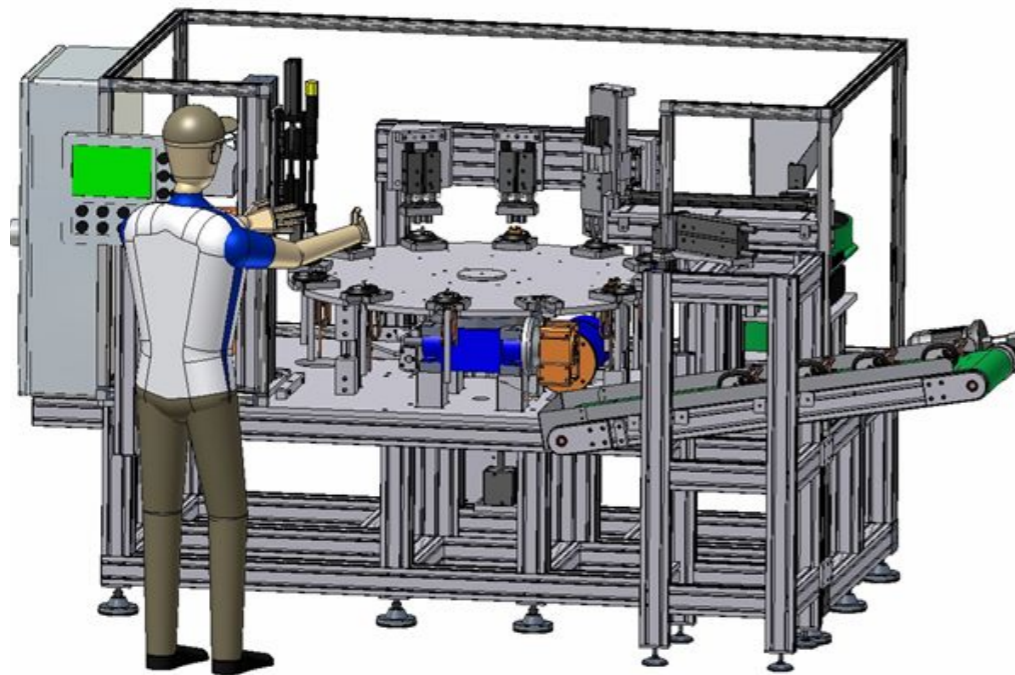
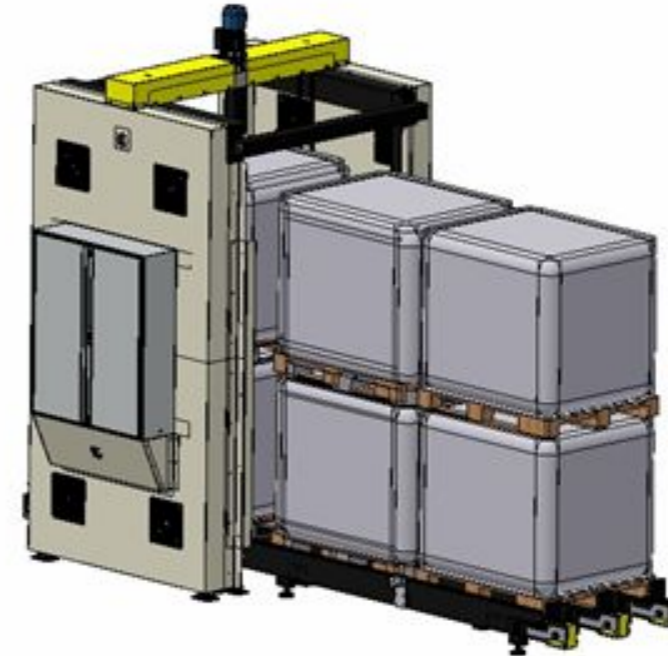
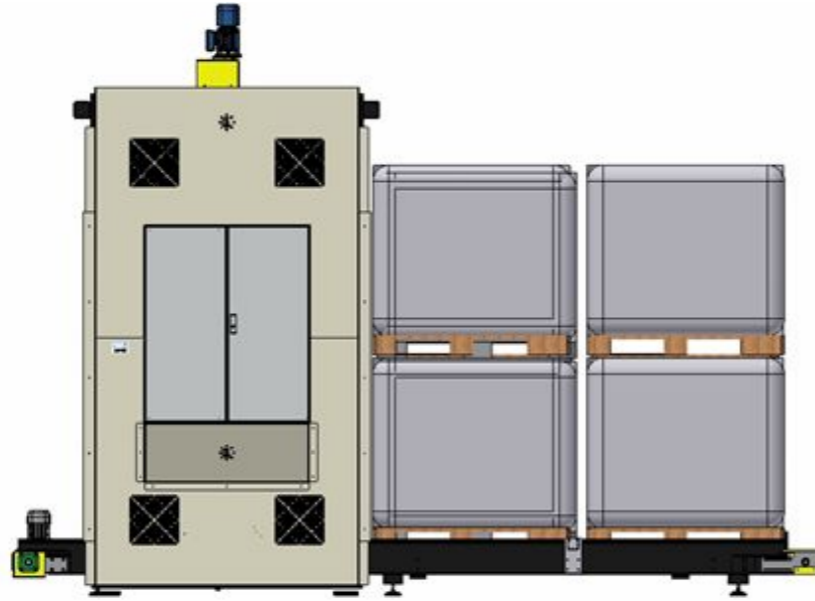



**Costruzioni
Meccaniche**

THE
BEST
OF **MADE
IN ITALY**



Member of CISQ Federation

RINA
ISO 9001:2008
Sistema Qualità Certificato



We created lines and production facilities of any kind, either manual or automatic for the world of appliances, ovens, dishwashers, refrigerators, washing machines, small appliances.

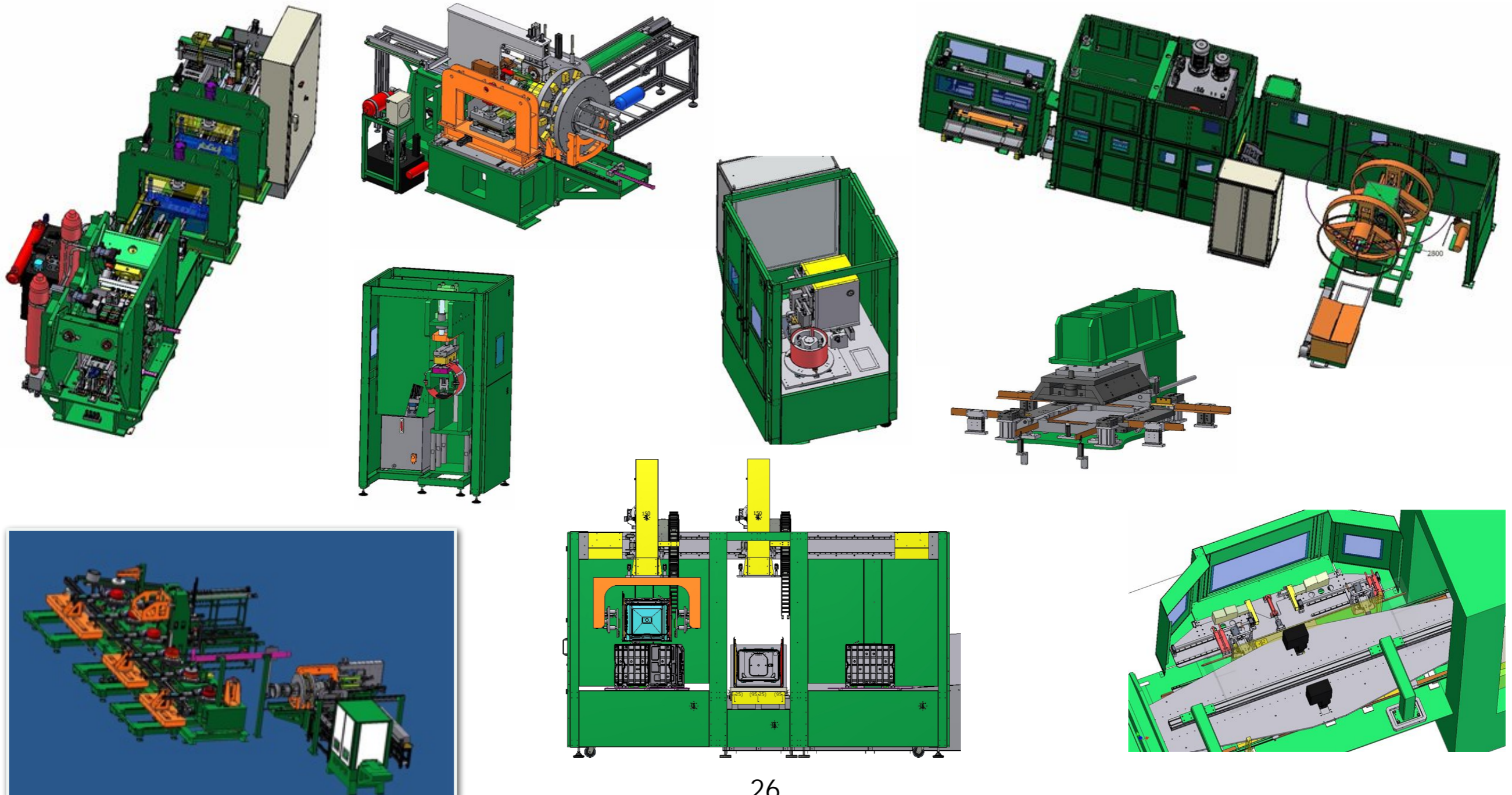

Other machine and service

- Marking machines up to 100 ton.
- Hydraulic press with integrated tool.
- Sheet metal forming machines
- Hydraulic press line up to 300 Ton, with or without transfer, Very speed and non very expensive.
- We can perform upgrades on older lines and presses.

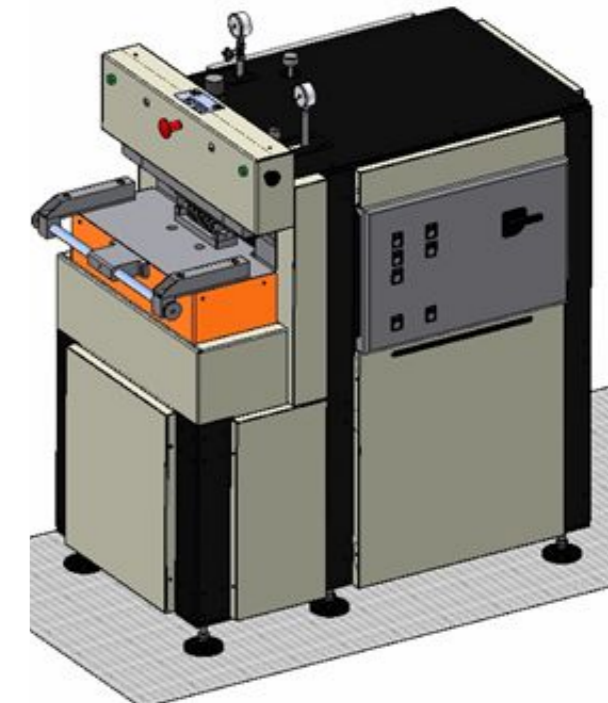
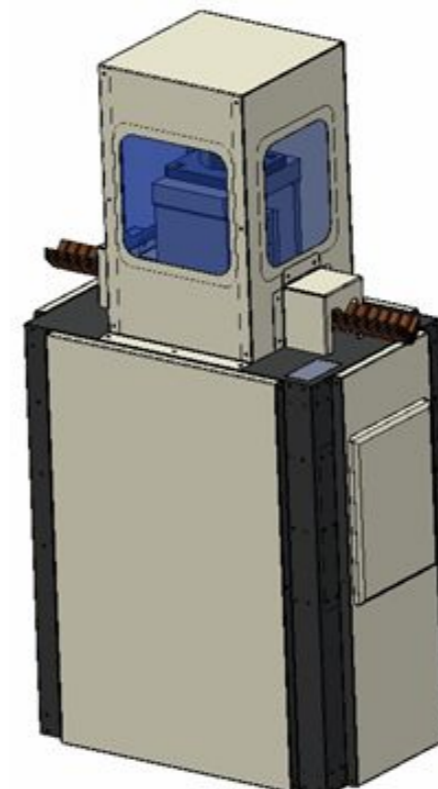
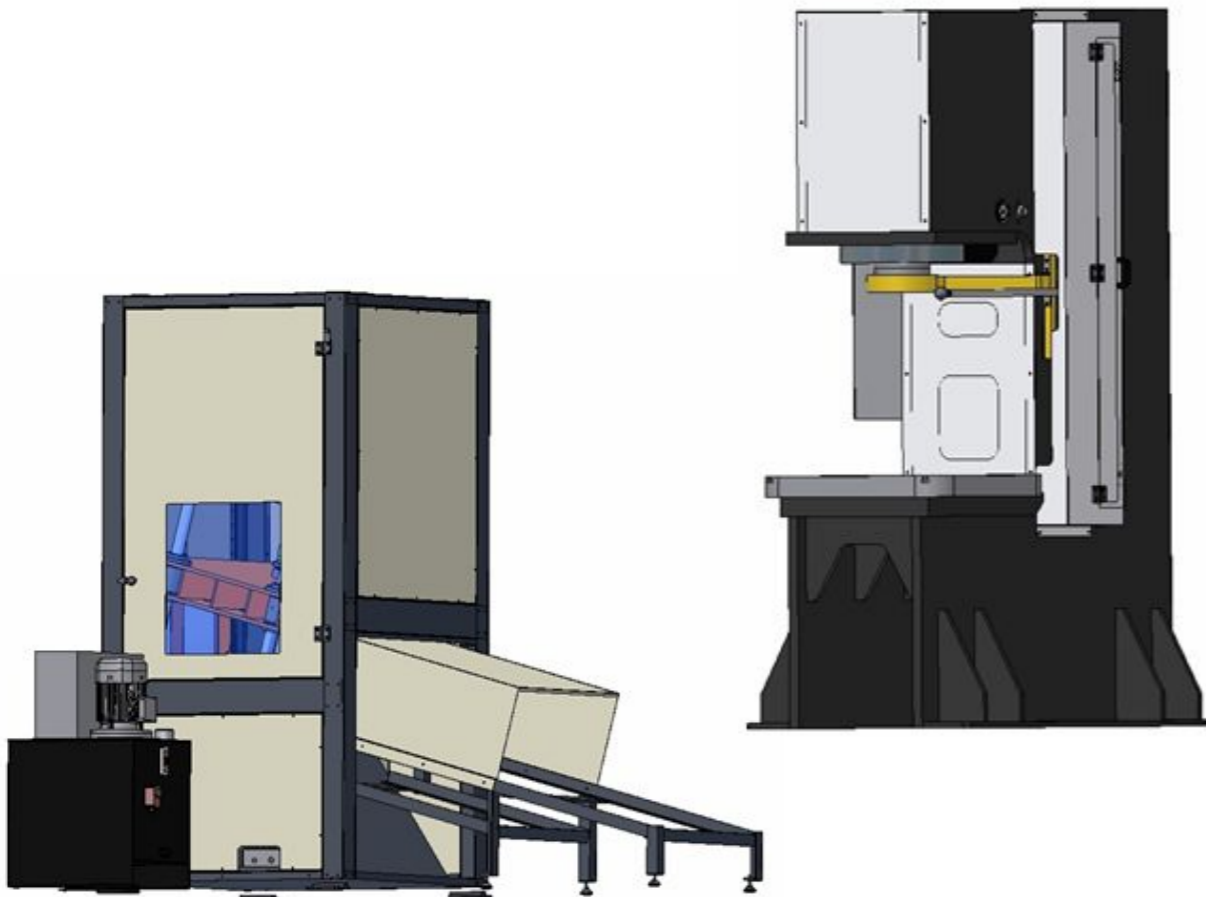
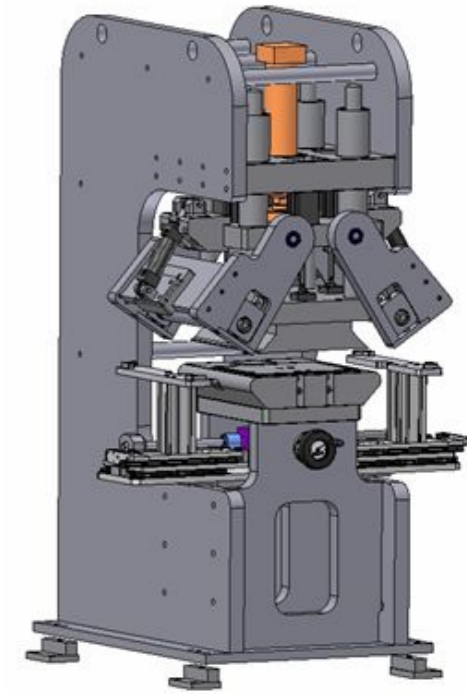
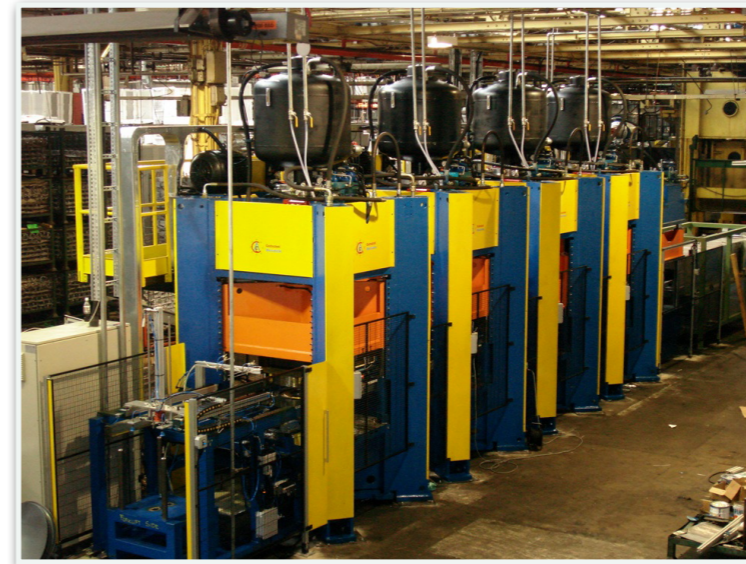

- Full automatic robotic grinding and polishing systems. With exclusive CAE system "Sense of Touch", for absolute and perfection results.
- Robotics welding system with MIG, TIG or Resistance
- Robotics load and unload (with or without tooling press).

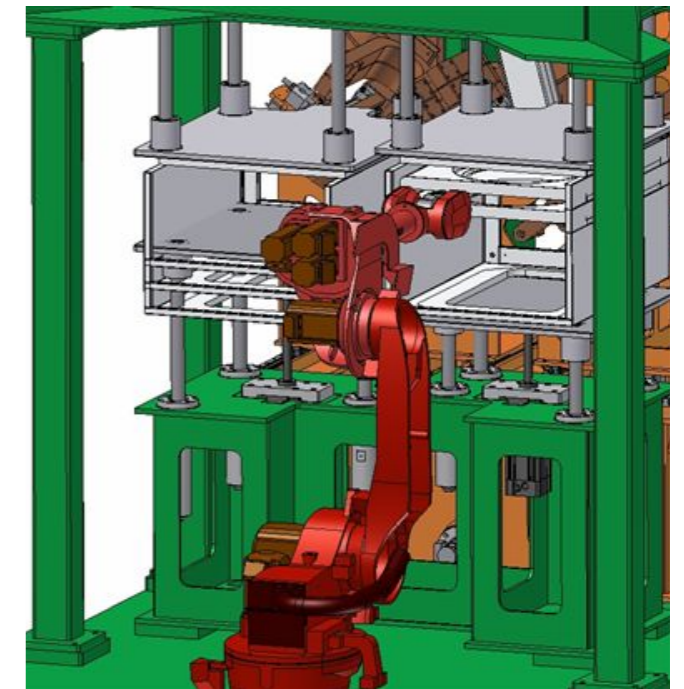
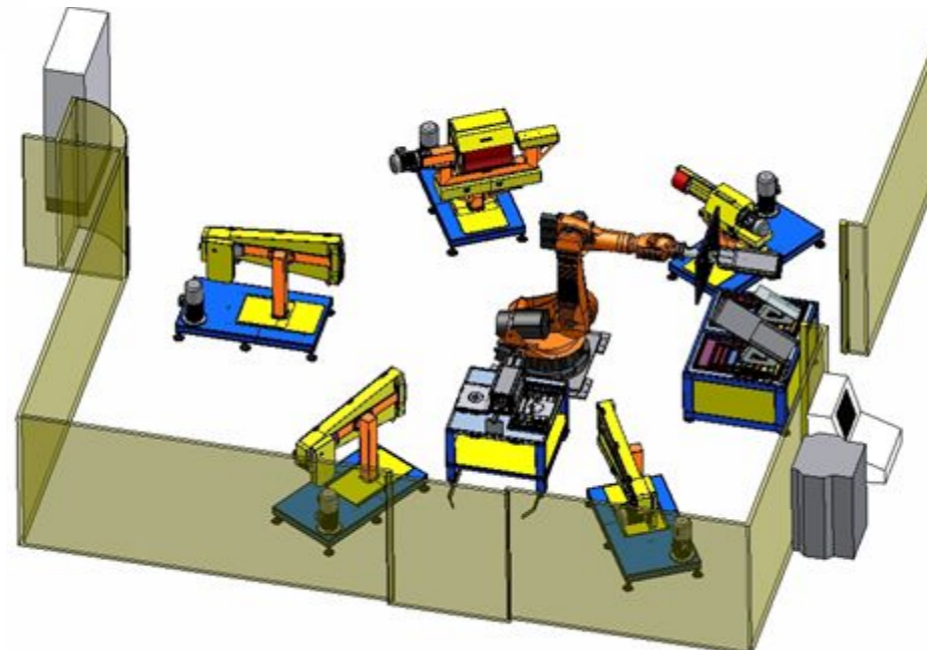
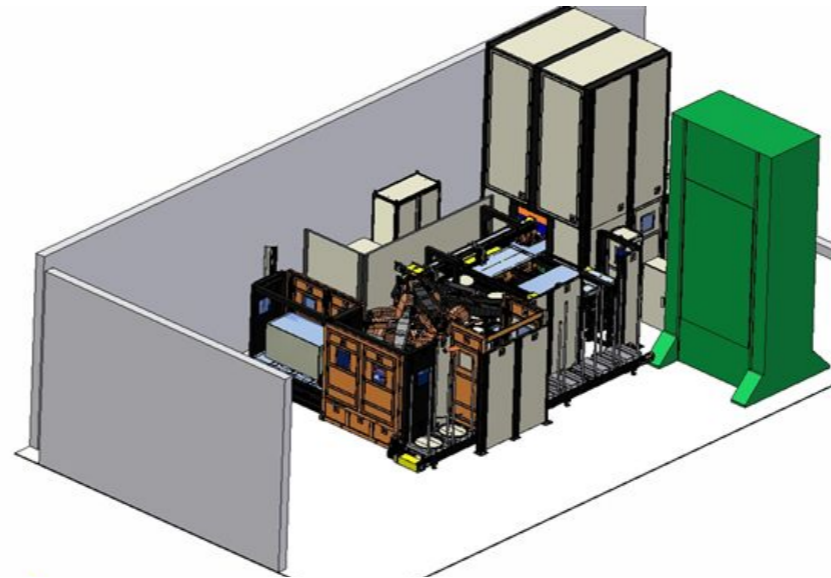
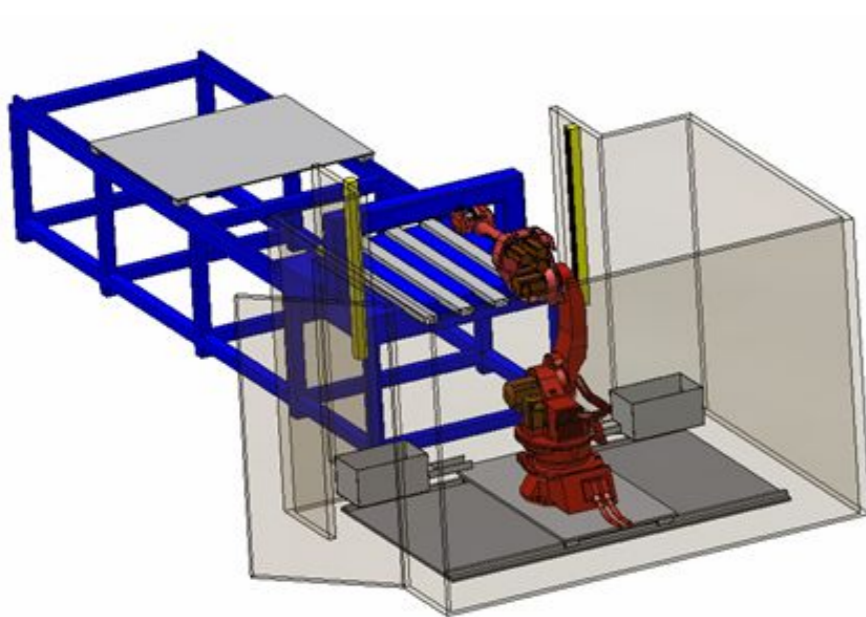

- Any kind of trasportation system: Roller, Belt, Chain, Magnetic...fully customize for your needs.

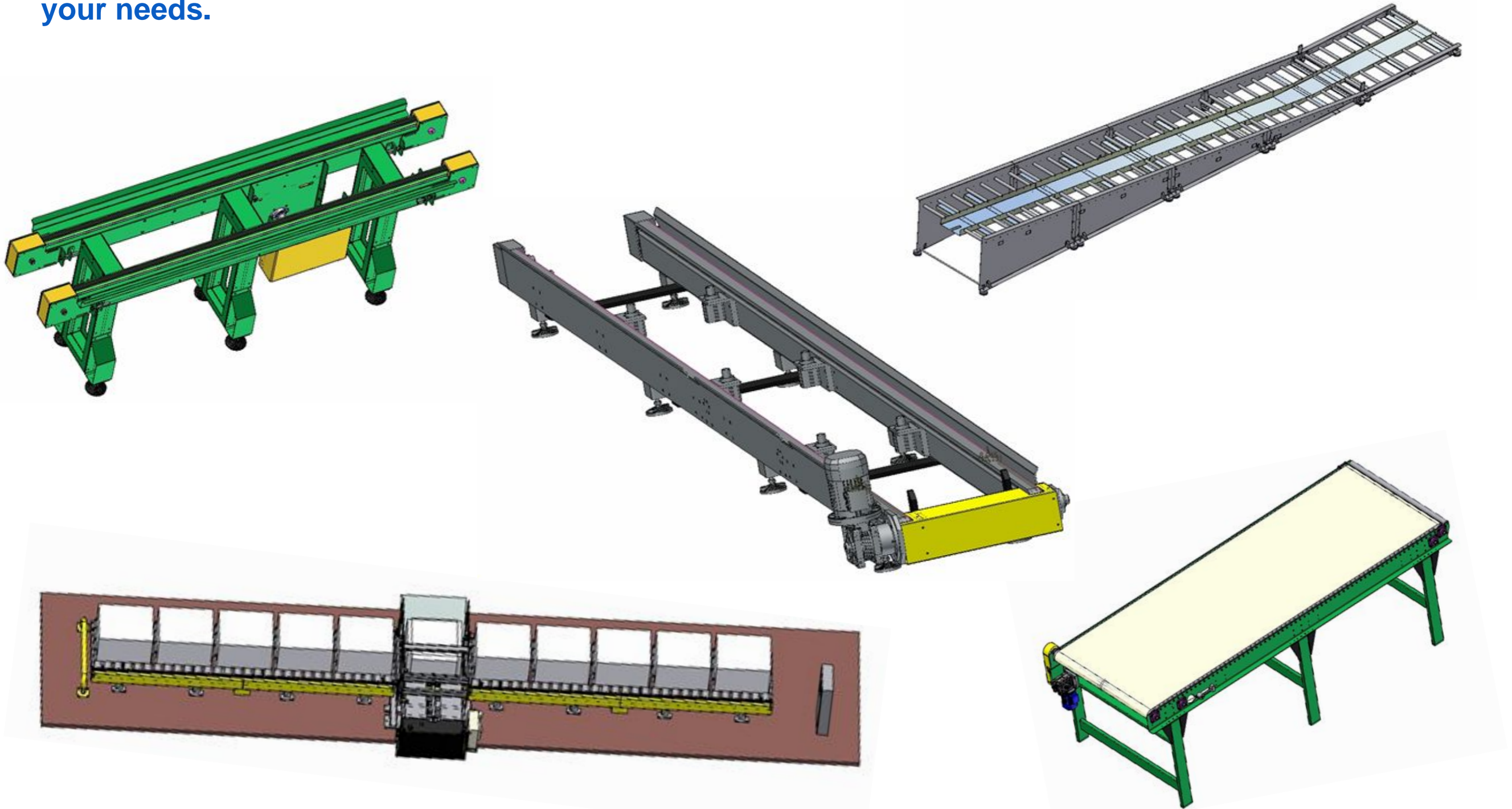

- Special metal drilling machine, manual or automatic for : angle, flat, square and rectangular tubes, and so on.
- Machines for sheet metal coils joining by TIG.

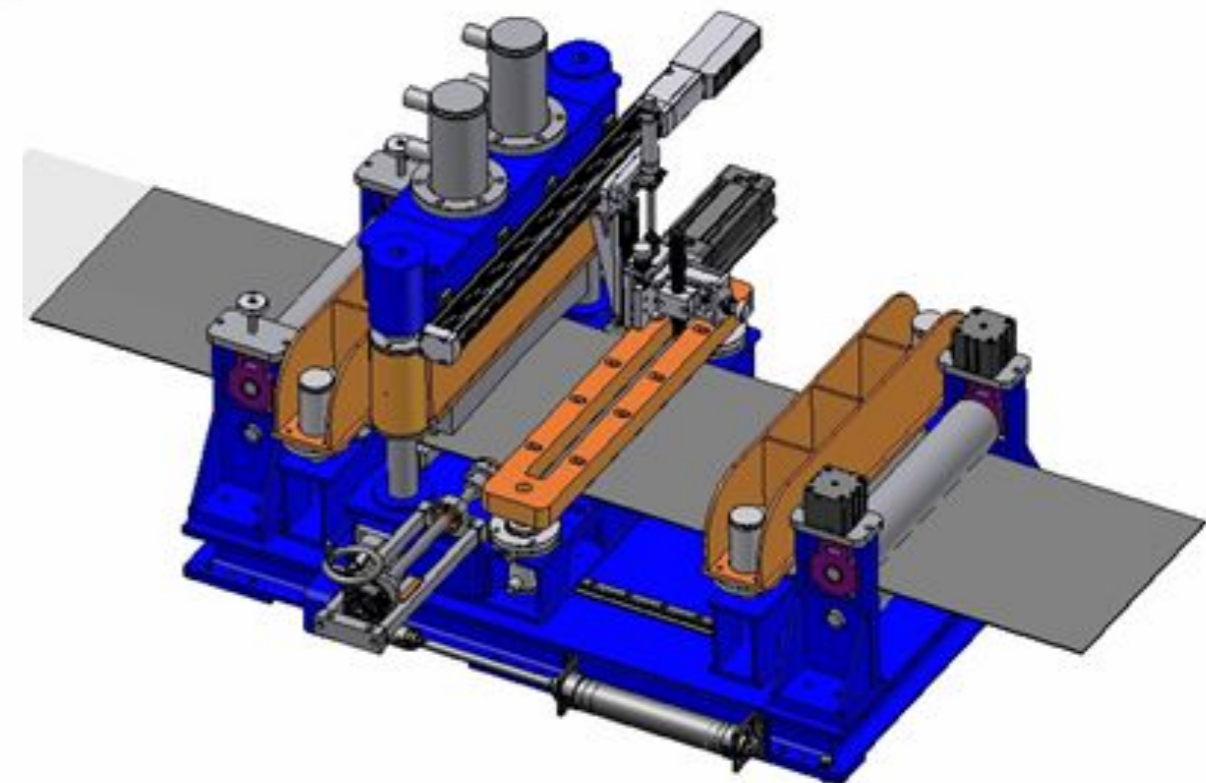
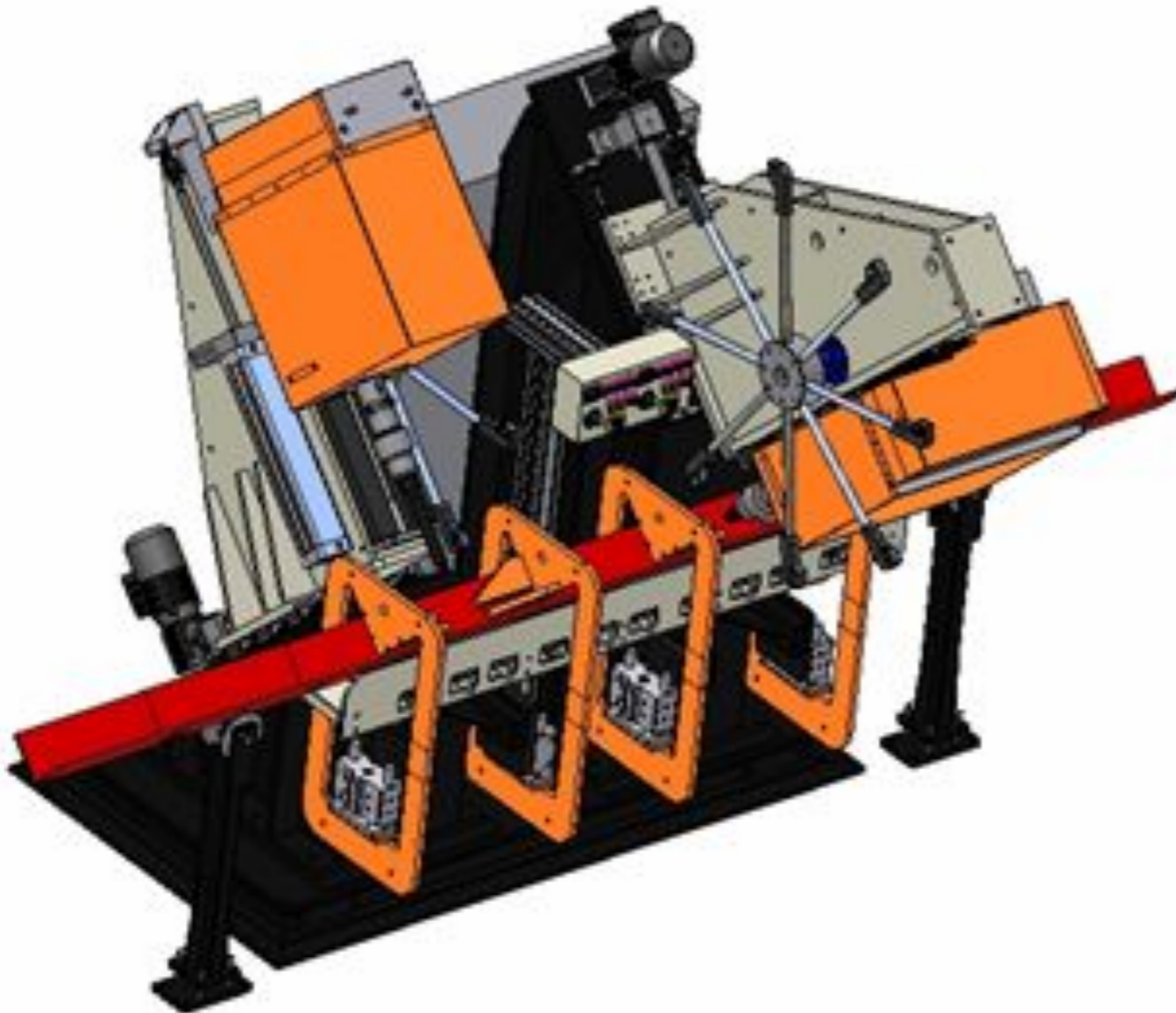

Machines for cleaning and treatment for idropower grids, and for the fish farming industry.

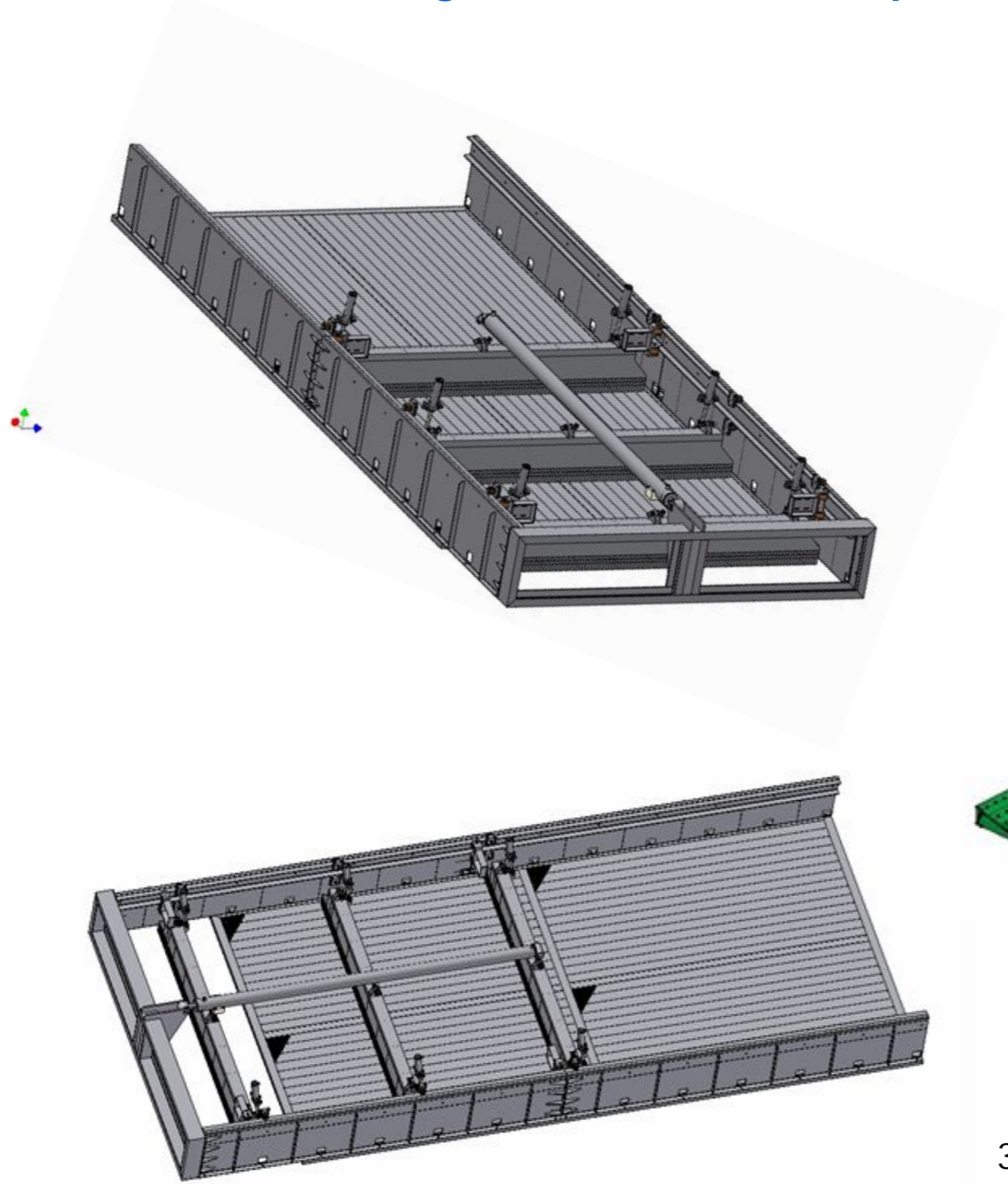

Brands that you will find in our machines



ifm electronic



Our major customer



Why choose CAE Mechanical Construction?

It 's the question that every day we do.

And it's always the same question that stimulates the thoughts and actions of all persons in CAE.

We always ask why, our customers continue to come from us, and we wonder if we can ever be content again.

We believe that these are the questions that then make us excel in what we do.

Or maybe it will be for incredible our availability in all circumstances, or for friendly atmosphere that reigns in the Company, or for respect for delivery dates and any contractual agreements.

Is it because if our machines have problems, we cannot ignore it and will can't sleep in the night, or because us will consider each machine as a creature where have participated all the staff and we are proud.

Is it because our guarantee is really something that the customer can count on.

Or is it because we take every all our responsibilities in any case and always, or can be because we have our CAE brand marked in some components, and then we get a double responsibility

It will be because our careful management of costs, making our prices very competitive, and the policy of our prices and always consistent and serious.

There are no fake margins for give you great discounts on negotiation. We have respect of your intelligence.

Maybe because we do not want to sell our products just for sell, and we like to advise the client on possible alternatives, when we realize that we can not be the best choice.

It will be our motto "Italian Passion for Automation" that is not just a rhyme a bit bizarre, but we all really passionate Italian Techicians who breathes every day in our "Factory of Ideas."

We can only invite you to know, without commitment.

If then we can propose something that meets your needs for put the groundwork for the start of a fruitful relationship for both, will simply that we will ask you: why you have chosen CAE?

Contact

- Direction office : fabrizio.cae.director@cae-cae.com
- Mobile: +39.335.8243641
- Secretary office : cae.contact.site@cae-cae.com
- Tel: +39.0737.889736
- Fax: +39.0737.889799

Sorry if you find our website in maintenance or not update. we are making one ones.

- www.cae-cae.com
- www.cae-cae.it

We are available to answer any question you may have and to provide you with references and price lists. We are looking forward to meeting with you, at your convenience, at our location or yours, to prove to you that we can satisfy all your machinery needs and provide you with our unsurpassed service.

Sincerely,
Mr. Fabrizio Galdelli

